

# Marshall Excelsior



## Gas Connections

---

### MEGR-1912 PRESSURE REGULATOR

#### **Instruction Manual- Look Inside For:**

- Description
- Installation
- Start-Up
- Maintenance
- Parts Ordering
- Parts List



#### **Marshall Excelsior Company**

Marshall, MI 49068

269-789-6700

FAX 269-781-8340

[www.marshallexcelsior.com](http://www.marshallexcelsior.com)

The contents of this publication are for informational purposes only. While every effort has been made to ensure accuracy, these contents are not to be construed as warranties or guarantees, expressed or implied, regarding the products or services described herein or for their use or applicability. Marshall Excelsior Co. reserves the right to modify or improve the designs or specifications of such products at any time without notice. The MEC™ logo is the trademark of Marshall Excelsior Co.

---

## **INTRODUCTION**

The MEGR-1912 regulator functions as an accurate pneumatic regulator with an adjustable set point. It is spring-loaded and self-relieved. Excessive output pressure will exhaust through the vent port, located on the regulated bonnet.

## **APPLICATIONS**

Applicable to a wide range of gaseous fluids, including air, propane and natural gas.

## **SPECIFICATION**

### **MATERIALS OF CONSTRUCTION**

Body, Bonnet - Zinc  
Diaphragm - Nitrile  
Diaphragm assembly - Zinc / Nitrile  
Gasket - Non-asbestos, CGR 2750  
Pin - Stainless steel  
Vent Screen - Monel  
Spring - Zinc-plated Steel  
Diaphragm Piston - Zinc-plated Steel

### **SPECIFICATIONS**

Inlet - 1/4" NPT  
Outlet - 1/4" or 3/8" NPT  
Temperature Range - -20° to 170°F  
Maximum allowable inlet pressure (PSIG) - 250  
Outlet Pressure Ranges - See Table 1  
Outlet Pressure Settings  
Approximate Weight - 1.3 lbs.

Table 1. Outlet Pressure Settings		
Outlet Pressure Range	Approximate range above outlet pressure setting at which internal relief starts to discharge	Spring Selection Color Code
3"-7" W.C. (7 to 17 mBAR)	5"-21" W.C. (12-52 mBAR)	Red
5"-10" W.C. (12 to 25 mBAR)	8"-30" W.C. (20-75 mBAR)	Orange
9.25"-13" W.C. (23 to 32 mBAR)	16"-39" W.C. (40-97 mBAR)	Cadmium
10" W.C. - 1.05 PSIG (25 to 69 mBAR)	17" W.C. - 3 PSIG (42-210 mBAR)	Blue
0.8 - 2.7 PSIG (55 to 186 mBAR)	0.7-6.8 PSIG (0.05 to 0.47 bar)	Yellow
2.7 - 5 PSIG (186 to 340 mBAR)	3.8-12.5 PSIG (0.26 to 0.86 bar)	Green

## **INSTALLATION**

Qualified personnel should perform installation, operation, and maintenance per NFPA 54 & 58 and local, State and Federal Regulations. The regulator can be mounted in any position, however the vent port of the bonnet should be pointed down. The flow through the body must be in the direction from inlet to outlet (inlet connection is marked on the body). Also make sure to position the regulator to prevent any contamination, rain and debris from entering the screened vent. Prior to installation inspect the regulator and the piping lines for any debris or contamination. After installation periodically inspect the regulator for damage, especially after any overpressure condition.

For indoor installation, if the regulator regulated the pressure of flammable or hazardous gas, a pipe should be connected to the tapped vent to discharge the exhausted gas to a safe area. A screened vent cap should be installed to the end of the pipe, which needs to be pointed down.

### **Warning!**

**In applications involving flammable or hazardous gases, the vented gas may accumulate and lead to fire or explosion. To prevent personal injury and property damage, it is necessary to vent the gas to a safe, well-ventilated area with piping or tubing. Periodically check the vent opening and line for any restrictions due to clogging or condensation.**

## **REMOTE VENT LINE INSTALLATION**

For remote venting, use the largest diameter piping possible. The pipe compound should be connected to the vent port by an adapter. Do not apply pipe compound to the internal body threads directly. For best results, limit the number of bends and keep the line as short as possible.

## **START UP AND ADJUSTMENT**

### **Warning!**

**The use of pressure gauges to prevent overpressure conditions, which might cause personal injury or equipment damage, is highly recommended. Before starting up the valve, relieve the downstream pressure on the diaphragm. Failure to do so may result in personal injury or equipment damage.**

When starting up the regulator, slowly open the upstream shutoff valve, and then slowly open the downstream shutoff valve. Check all piping and connections for leaks before making any final pressure adjustments. The nameplate provides the range of allowable pressure settings. For pressure settings outside the allowable range, change to appropriate range spring and remember to change the nameplate accordingly.

**Note: The use of a pressure measuring device is highly recommended when making any pressure adjustments with the regulator.**

When the output pressure adjustment is needed, remove the closing cap and insert a screwdriver blade into the adjusting screw. Slowly turn the adjusting screw clockwise (downward) to increase or counterclockwise (upward) to decrease the output pressure setting. Replace the cap when the pressure adjustment is done.

## **SHUTDOWN**

Close the upstream shutoff valve first, then close the nearest downstream shutoff valve.

## **MAINTENANCE**

Severity of conditions and the requirement of both state and federal laws determine the frequency to which the relief valves need to be inspected. Debris in the process line, exterior damage, and normal wear could require the replacement of parts such as the diaphragm assembly. The procedures below will provide assistance when attempting to replace these parts.

### **Warning!**

**When attempting any inspection or disassembly, relieve all pressure from the relief valve and its adjacent piping so as to prevent personal injury or equipment damage as a result of an explosion or sudden pressure release.**

### **Range Spring Replacement**

Remove the closing cap and turn the adjusting screw out of the bonnet. Replace the range spring and thread the adjustment screw back. Assure the adjustment screw to be lined up with the range spring. Replace the closing cap.

### **Diaphragm and Relief Valve Replacement**

Remove closing cap and adjustment screw. Loosen the machine screws and remove the bonnet. Disengage the diaphragm subassembly from the regulator. Dismantle the diaphragm subassembly by pressing down the spring seat and removing the pin.

## **PART ORDERING**

When ordering replacement parts, always reference the part number, which is found on the nameplate.

## **PARTS LIST**

ITEM	DESCRIPTION	QTY
1	Body, 3/8" Port	1
	Body, 1/4" Port	1
2	Arm Assembly	1
3	Rod	1
4	Machine Screw 5/16	2
5	Machine Screw 3/8	6
6	Backup Spring	1
7	Pin	1
8	3-7" W.C. Range Spring, Red	1
	5-10" W.C. Range Spring, Orange	1
	9.25-13" W.C. Range Spring, Cadmium	1
	10"W.C.-1.05 PSIG Range Spring, Blue	1
	0.8-2.7 PSIG Range Spring, Yellow	1
9	Bonnet	1
10	Closing Cap	1
11	Gasket	1
12	Adjusting Screw	1
13	Spring Seat	1
14	Screen	1
15	Diaphragm Piston	1
16	Poppet	1
17	Diaphragm	1

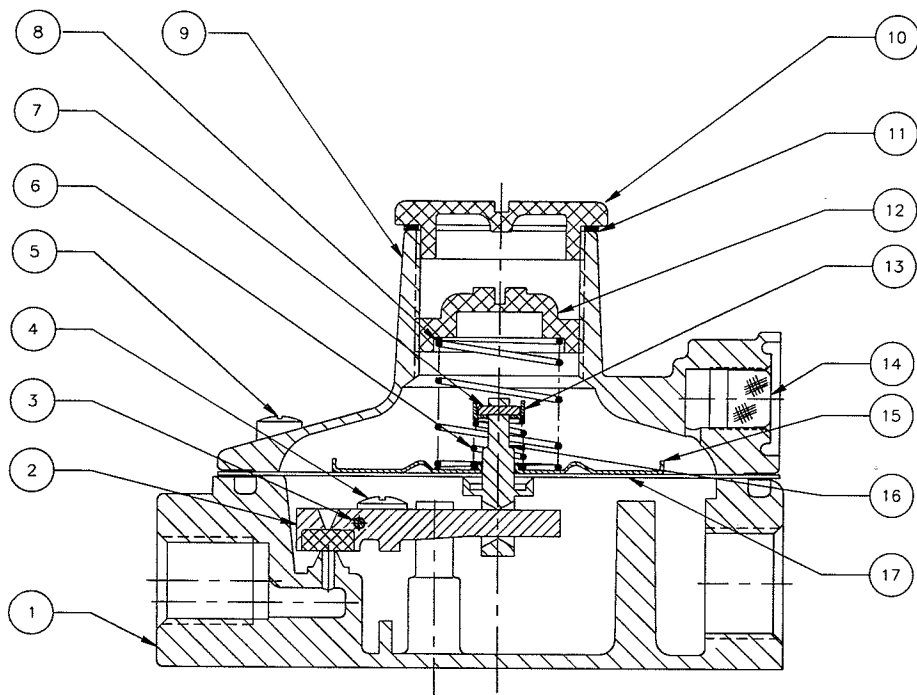

**Figure 1**