



ME990S-2F-16 AND ME990S-2DFM 2" FLANGED INTERNAL VALVE INSTALLATION AND OPERATING MANUAL



!WARNING!

Failure to follow these instructions or to properly install and maintain this equipment could result in an explosion and/or fire causing property damage and personal injury or death.

MEC equipment must be installed, operated, and maintained in accordance with federal, state, and local codes and manufacturer's instructions. The installation in most states must also comply with NFPA No. 58, and ANSI/CGA G-2.1.

For installation in the European Union, the equipment must also comply with PED/TPED and EN ISO standards. Periodic inspections, intermediate inspections and exceptional checks of transportable pressure equipment should be carried out in accordance with the Annexes of Directive 2008/68/EC and with 2010/35/EU Directive (TPED) to ensure continued compliance with their safety requirements.

Only personnel trained in the proper procedures, codes, standards, and regulations of the LP-Gas industry should install and service this equipment.

The internal valve must be closed except during product transfer. A line break downstream of a pump may not actuate the excess flow valve. If any break occurs in the system or if the excess flow valve closes, the system should be shut down immediately.



WARNING: These products contain a chemical known to the state of California to cause cancer and birth defects or reproductive harm

Scope of the Manual

This manual covers instructions for the ME990S-2F-16 and ME990S-2DFM "Excelerator" Series 2" single and double flange internal valves.

Introduction

ME990S-2F-16 and ME990S-2DFM "Excelerator" Series Internal Valves are designed to provide accelerated equalization of tank pressure and downstream line pressure, providing fast valve response time for quick opening. These internal valves are frequently used on bobtail and transport truck tanks for liquid gas delivery, but they may also be used on large stationary storage tanks and on in-line installations in liquid or vapor gas transfer applications. U.L. listed types are designed for use with Propane or NH₃ (Anhydrous Ammonia) services. Non U.L. listed models are available with a variety of trim types and body styles and can be used on other compressed gases, but the installer should check with the factory to make sure the valves are suitable for the particular service.

Marshall Excelsior Company

1506 George Brown Drive Marshall, MI 49068
Phone (269) 789-6700 Fax (269) 781-8340

www.marshallexcelsior.com

MEC Europe AsP

Alsvej 21
8940 Randers SV
Denmark

The contents of this publication are for informational purposes only. While every effort has been made to ensure accuracy, these contents are not to be construed as warranties or guarantees, expressed or implied, regarding the products or services described herein or for their use or applicability. Marshall Excelsior Co. reserves the right to modify or improve the designs or specifications of such products at any time without notice. The MEC™ logo is the trademark of Marshall Excelsior Co.



ME990S-2DFM

ME990S-2F-16

Actuation of the valve can be achieved manually, by cable, or with a pneumatic actuator.

Features

- **Excelerator equalization bleed area** - Provides high bleed flow for quick opening.
- **Unique Serviceability Features** - Accessible stainless steel stem hex and socket drive retaining screws for easy maintenance.
- **Durable Design:**
 - Stainless poppet and stem with hardened, low friction coating operates smoothly for a long wear life
 - Fully captured main seal and molded-on bleed seal will not "Blow-out"
 - Large poppet retaining thread will not break during reverse flow fill
 - Integral travel stop
 - Stainless steel roller cam
- **Excess Flow Closure** - Functions when flow exceeds the rated capacity of the valve or piping is sheared off at the valve.
- **Back Check Feature** - Allows reverse flow filling with or without actuator device in valve open position.
- **Spring loaded Polytetrafluoroethylene (PTFE) stub shaft packing with auxiliary wiper seals**
- **Rulon® bushings at critical wear points.**
- **Manual, Cable, or Air Open/Close valve actuators.**
- **Thermal Fusible links or plugs melt at 212°F (100°C) and allow valve closure in the event of a fire at the valve.**

ME990S-2F-16 and ME990S-2DFM

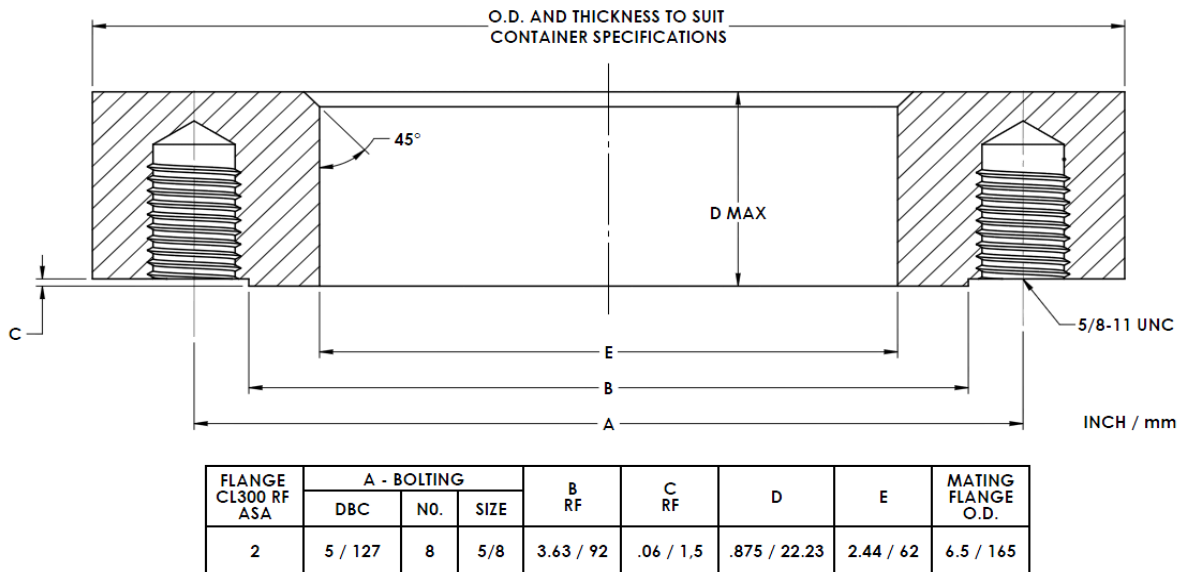

FIGURE 1: TANK FLANGE DIMENSIONS

Description

ME990S-2DFM: The ME990S-2DFM double flanged internal valve is intended for special bobtail truck applications where the pump must be lowered to clear the truck frame or other obstacles. A shear section in the lower body permits the valve to shear off in the event of an accident, leaving the shutoff within the tank.

ME990S-2F-16: The single flanged ME990S-2F-16 internal valve is used on transport trucks and eliminates the threaded tank connection required for threaded valves.

Internal valves can be used with transports and on stationary storage tanks. The valves can be operated by cable or with air.

Designed for use with Propane or Anhydrous Ammonia at ambient temperatures, the valves can be used on other compressed gases, but the user should check with the factory to make sure the valves are suitable for the particular service and application.

Specifications

Specifications

Body Size and End Connection Styles:

ME990S-2F-16, and ME990S-2DFM Inlet:

2-inch CL300 RF Flange
(3 5/8-inch / 92 mm diameter bore)

ME990S-2F-16 Outlet: 2" FNPT

ME990S-2DFM Outlet: 2-inch CL300 RF Flange

Maximum Allowable Inlet Pressure:

500 psig / 34.5 bar WOG

Excess Flow Springs

Half Coupling Flows:

2" (vertical down): 110, 160 & 260 gpm
(416, 606, 984 lpm)

Temperature Capabilities:

-20° to 150°F / -29° to 66°C

Approximate weight:

ME990S-2F-16: 20 pounds / 9 kg

ME990S-2DFM: 30 pounds / 14 kg

DOT Internal Self-Closing Stop Valve Requirement:

U.S. Department of Transportation (DOT) regulations 49CFR§178.337-8(a)(4) require each liquid or vapor discharge outlet on cargo tanks (except for cargo tanks used to transport chlorine, carbon dioxide, refrigerated liquid, and certain cargo tanks certified prior to January 1, 1995) to be fitted with an internal self-closing stop valve. MEC ME990S Series internal valves comply with the internal self-closing stop valve requirement under the DOT regulations.

Installation

Internal Valve

Coat both sides of the spiral wound gaskets with Dow Corning #111 silicone grease or equivalent. A 2-inch ASME CL300 RF flange with a modified bore (see Figure 1) must be installed in the tank. Special stud bolts, furnished with the valve, are assembled into this flange. The internal valve and the pump or piping flange can then be installed as shown in Figure 2.

On valves so equipped, the filter screen should be removed if the valve is to be used for both filling and withdrawal service or for filling alone. Filling with the filter screen installed is not recommended.

ME990S-2F-16 and ME990S-2DFM

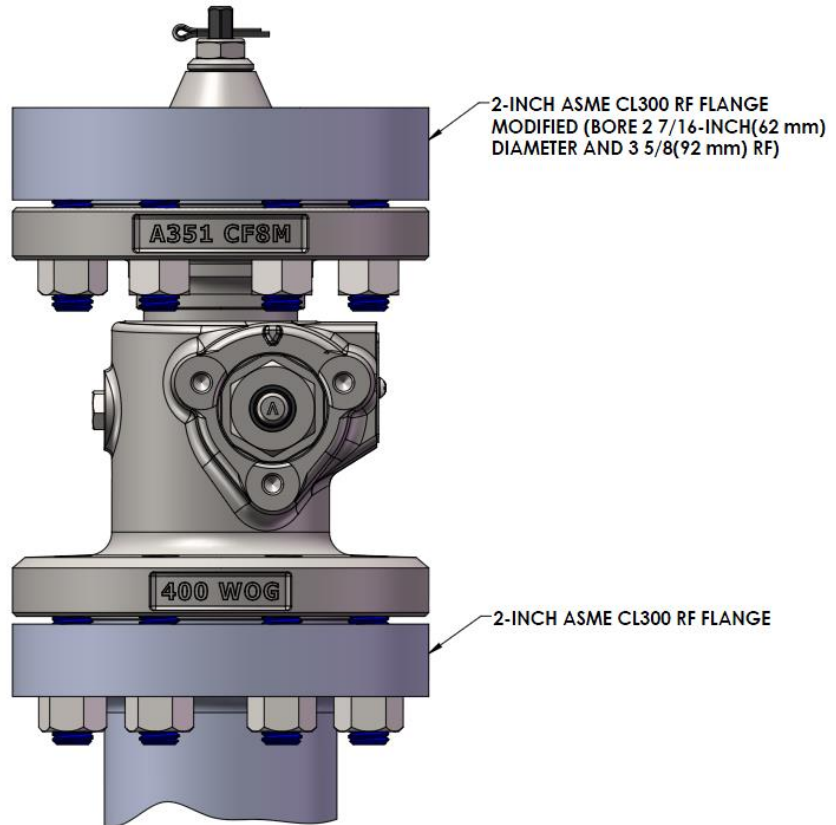

FIGURE 2: ME990-2DFM TYPICAL VALVE INSTALLATION SCHEMATIC

A hydrostatic relief valve does not need to be installed adjacent to the valve since the internal valve automatically relieves excessive line pressure into the tank.

Keep piping from the valve outlet to the pump full size and as short as possible with a minimum number of bends. Reduction in pipe size to suit smaller pump inlets should be made as close to the pump as possible using forged reducers (swage nipples) or venturi tapers rather than bushings. This assures minimum flow resistance and efficient pump operation.

If the valve is also used to provide excess flow protection, the flow rating of the piping, fittings, pump, valves, and hose on both the inlet and outlet of the internal valve must be greater than the flow rating of the integral excess flow valve within the internal valve. If branching or other necessary restrictions are incorporated in the system which reduces the flow rating to less than that of the excess flow valve rating, the internal valve will not give excess flow protection.

After installation check all joints for leaks using a suitable leak detector solution such as Marshall Excelsior low-temp leak detector before putting the valve into service.

Selectively Filling Manifolded Tanks

MEC internal valves provide positive shutoff in only one direction, from out of the tank to downstream of the valve. The internal valves are designed to allow gas to flow into a tank when the downstream line pressure exceeds tank pressure. If you want to selectively fill one

or more of the other tanks in a tank manifold system, you must place a positive shutoff valve downstream of the internal valve, otherwise, all tanks will be filled at the same time and at about the same rate.

Actuators

The remote operating control system for the internal valve is extremely important, and it must be installed to conform with the applicable codes. DOT MC331, for example, most generally applies for trucks. MEC offers both cable controls and pneumatic actuator systems to operate the internal valves. It may also be possible to use cable controls from other manufacturers or to fabricate a linkage mechanism.

Any control system requires thermal protection (fuse links) at the valve, at the remote control point and, if necessary, near the hose connections. The instruction manuals for MEC actuator systems show how to install the fuse links.

Installation instructions on MEC MEP650 (Cable Control Mechanism) are in Form #935, ME980-905-25 and ME980-905-50 (Remote Release) are in Form #941. Pneumatic actuator installation is covered in Form #401 and Rotary actuator installation is covered in Form #462. ME990-24 latch/remote release instructions are in Form #934.

The operating linkage must allow the operating lever to move from the fully closed position to within 2° of the fully open position. The linkage should not apply strong force to the lever past the fully open position or the valve could be damaged.

Note

The use of non-MEC actuators may result in leakage of the gland packing caused by premature wear. In addition to premature wear, the use of non-MEC actuators may result in lower than expected flow rates and possible leakage across the valve seats.

!CAUTION!

The internal valve's closing spring is not designed to overcome drag in the control linkage in order to close the valve. Depending upon the control system used, an external spring or positive closing linkage may be needed. Be sure the control system is installed to prevent binding that could cause the valve to stick in the open position.

Excess Flow Operation

The internal valve contains an excess flow function, or "integral excess flow valve," that is designed to close when the flow exceeds the flow rating established by MEC. MEC's integral excess flow valves installed on a bobtail truck or transport can provide protection against the discharge of hazardous materials during an unloading operation. Provided the tank pressure produces a flow greater than the valve's excess flow rating, the internal valve will close in the event the pump or piping in line with the valve is sheared off.

Likewise, if the internal valve is installed on a stationary tank or in the related downstream piping system, the integral excess flow valve can provide protection against an unintentional release of hazardous materials in the event that a pump or piping attached directly to the internal valve is sheared off before the first valve, pump, or fitting downstream of the internal valve, provided that the flow of product through the internal valve reaches the rated flow specified by MEC.

!CAUTION!

In the event of a ruptured hose or piping at a point in the discharge system downstream from the first valve, pump or the internal valve, the excess flow feature is designed to close upon a significant increase in differential pressure or flow. Restrictions incorporated in the discharge system of a bobtail truck, transport or a stationary tank, may include but not limited to pumps, pipe and hose length and dimensions, branching, elbows, reductions in pipe diameter, or a number of other inline valves or fittings. Low operating pressure may be a result of ambient temperature, or a partially closed valve downstream from the integral excess flow valve; this can restrict the rate of flow through the internal valve below the level necessary to actuate the integral excess flow valve. Therefore, **DO NOT RELY ON** the excess flow function of the internal valve for the purpose of providing protection against the discharge of hazardous materials, when other downstream restrictions are present in the system.

The internal valve is designed with an internal bleed feature for equalization of pressure. After the integral excess flow valve closes, the leakage through the bleed must be controlled or a hazard can be created. For this

reason the operator must be familiar with the closure controls for the internal valves and must close the internal valve immediately after the integral excess flow valve closes.

Failure to follow this warning could result in serious or fatal personal injury or property damage from a fire or explosion.

DOT Passive Shutdown Equipment Requirement - DOT regulations 49 CFR§173.315(n)(2) require certain cargo tanks transporting propane, anhydrous ammonia and other liquefied compressed gases to be equipped with passive emergency discharge control equipment that will automatically shut off the flow of product without human intervention within 20 seconds of an unintentional release caused by complete separation of a delivery hose. The design for each passive shutdown system must be certified by a Design Certifying Engineer (DCE) and all components of the discharge system that are integral to the design must be included in the DCE certification. The DCE certification must consider any specifications of the original component manufacturer. In the case of downstream ruptures in hose or piping, a variety of operating conditions routinely encountered during an unloading operation restrict the rate of flow through the integral excess flow valve and make such a valve unsuitable to serve as the means of passive shutdown required under 49 CFR§173.315(n)(2). Such variables include restrictions incorporated in the discharge system (due to pumps, pipe and hose length, dimensions, branching, elbows, reductions in pipe diameter, or a number of other in-line valves or fittings), low operating pressure as a result of ambient temperature, or a partially closed valve downstream from the excess flow valve. Due to the variety of conditions, in the case of a hose separation, that can restrict the rate of flow below the level necessary to activate the excess flow valves, the integral excess flow function of MEC ME990S internal valves cannot be used to satisfy the passive shutdown equipment requirement under/in 49 CFR§173.315(n)(2). Also, a Design Certifying Engineer cannot include the integral excess flow valve of a MEC ME990S internal valve as a component of the discharge system in any DCE certification under 49 CFR§173.315(n)(2).

!EXPLOSION HAZARD!

DO NOT USE the excess flow function incorporated into MEC ME990S internal valves to satisfy the passive shutdown equipment requirement in 49 CFR§173.315(n)(2). **DO NOT** include the excess flow function incorporated into MEC ME990S internal valves in a DCE certification under 49 CFR§173.315(n)(2). The cargo tank manufacturer must install some other equipment that satisfies the requirement for passive shutdown capability under 49 CFR§173.315(n)(2).

Failure to follow this warning could result in serious or fatal personal injury or property damage from a fire or explosion in the event of an unintentional release of product during an unloading operation.

ME990S-2F-16 and ME990S-2DFM

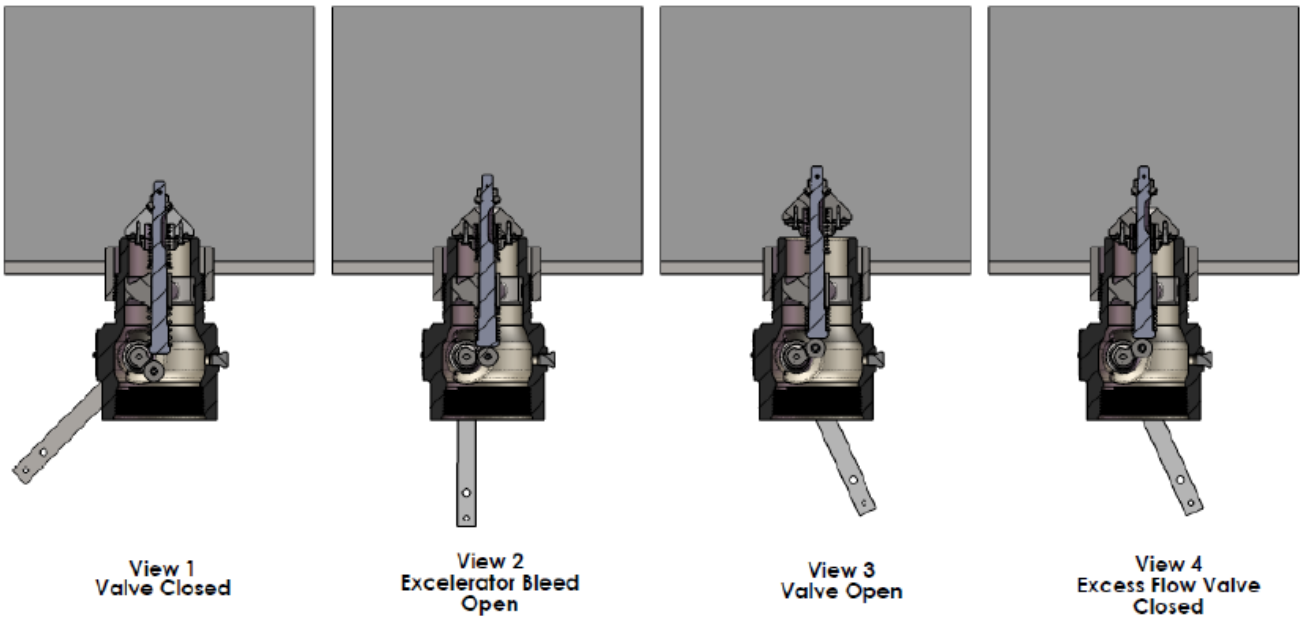

Figure 1: Operational Schematic

Operation

Since the ME990S-2F-16 and ME990S-2DFM Series Internal Valves are most often used on bobtail trucks, the following procedure applies to that type of application. Follow these steps:

1. ME990S series internal valves on bobtails and transports should never be open when the truck is in motion. If the control system is not interlocked to prevent this, the operator is responsible to ensure that the valves are closed.
2. Always open the internal valve before opening any other valves in the line or starting the pump.
3. Move the lever to the half-open (rapid equalizing) position (Figure 3, View 2) to equalize pressure. When the main poppet clicks open, move the operating lever fully open.
4. Open other line valves slowly to avoid sudden surges which could slug the excess flow valve shut.
5. If the excess flow valve does close, stop the pump and close the nearest downstream valve. Move the internal valve's operating lever back to the rapid equalizing position (outlined in step 3) and wait for the valve to click open. Then move the operating lever fully open and slowly open the downstream valve.
6. All valves should be completely open when pumping. (Throttling type valves could prevent the excess flow valve from closing when required.)
7. The operator must always be aware of where the remote closure controls are located and know how to operate the controls if an emergency requires valve closure. When pumping is finished, make a habit of closing the internal valve from the remote closure point, thus checking to see that the control actually is capable of closing the valve and operating correctly.
8. The valve should be open when backfilling through the valve to fill the tank.

Troubleshooting

Internal Valve Will Not Open: This could be due to leakage downstream, engaging the pump too soon or from excessive wear in the internal valve. If excessive volume is

In the downstream system, a longer time is required to equalize the pressures (tank and downstream) before the pump can be engaged. To determine if the valve pilot seat is opening, install a gauge downstream of the valve, operate the valve actuator; if pressure does not build up to the tank pressure, the valve pilot seat is not open. This test should be done with the pump off. If the pilot is not opening, it may be plugged with dirt or some internal part may be broken. If by operating the lever manually it can be rotated past the fully open position, there is something wrong internally and the valve must be disassembled.

Premature Valve Closure: This can be caused from engaging the pump too soon, by an underrated excess flow valve spring, or by an improperly connected internal valve operating lever which does not fully open the valve. The trouble could also be from a valve that has its inlet port obstructed or from sudden line surges. In order to check the valve opening travel, operate the lever manually to the full travel, wait until valve opens (usually about 15 seconds), then engage the pump. If the excess flow closes, the points mentioned above should be investigated.

Internal Valve Will Not Close: The stub shaft could be binding or the stem could be bent in the valve. Before disassembling the valve, check the actuator mechanism to see that it operates freely by disconnecting it from the valve lever and cycling it several times. Also, operate the valve lever manually. If it sticks in the open position, the packing and bushings should be replaced. This should free the operating mechanism if the valve has not been damaged internally. Refer to the "Maintenance" section.

ME990S-2F-16 and ME990S-2DFM

Low Flow Capacity: This could be caused by an undersized internal valve, undersized or long downstream piping, plugged screens, some other restriction in the downstream system, or by the bypass valve sticking in the open position. The bypass valve could also be set too low and be opening prematurely.

Principle of Operation (Figure 3)

The operational schematic depicts threaded valves, however flanged styles operate in the same manner.

Refer to the schematic drawing, Figure 3. In Figure 3, View 1, the valve is held closed by both tank pressure and the valve's closing spring. There is no leakage past the resilient seats in the poppet to the valve outlet in this position.

The valve is opened by moving the operating lever to approximately midpoint in its 70° travel (Figure 3, View 2). This allows the cam to place the rapid equalization portion of the valve stem in the pilot opening, permitting a larger amount of product to bleed downstream than if the operating lever was moved to the full open position.

When tank and downstream pressures have equalized in the bleed position, (after a few seconds), the excess flow spring pushes open the main poppet (Figure 3, View 3) and the operating lever can be moved to the full open position.

If tank pressure is greater than the valve's outlet pressure, the main poppet will remain in the closed position. If valve outlet piping is closed off by other valves, however, product bleeding through the pilot will increase until it nearly equals tank pressure and the main poppet opens.

Note

The main poppet will not open if valve outlet piping is not closed off so that the outlet pressure can approach tank pressure.

Once the main poppet opens, a flow greater than the valve's excess flow spring rating or a sufficient surge in flow forces the main poppet closed against the excess flow spring (View 4). The pilot valve allows a small amount of product to bleed, but much less than View 2 where the rapid equalization portion of the stem is placed in the pilot opening. When the operating lever is moved to the closed position, the valve closes completely and seals tightly (View 1).

Maintenance

!CAUTION!

Do not use these internal valves if they leak, fail to work properly, have been damaged or have missing parts. Prompt repairs should be made by a properly trained serviceman. Continued use without repair can create a hazardous situation which could result in serious or fatal personal injury or property damage.

A simple preventative maintenance program for the valve and its controls will eliminate many potential problems.

MEC recommends these steps be conducted once a month. Also refer to the Department of Transportation (DOT) CFR 49 Sections 180.416 and 180 Appendix A and B which specify monthly maintenance and inspection tests for cargo tank service internal valves and their actuation controls.

1. Inspect the operating lever to see that it operates freely and that there is no leakage around the retainer nut. If there is sticking or leakage, replace the packing and bushings. Refer to parts list.
2. Check for tight closure of the seat discs. Any detected leakage, which is normally caused by disc wear, dirt, scale or debris embedded in the disc, requires that the internal valve be removed from service and repaired. Repair most often requires the replacement of valve discs. To check for leakage:
 - a. Close the internal valve and exhaust downstream pressure. Close the first valve downstream from the internal valve and note any pressure build-up using a pressure gauge, between the closed valve and the internal valve. If piping is cold allow it to warm to ambient temperature.
 - b. Refer to CFR 49 Section 180 Appendix B for Meter Creep Test Methods.
3. All operating controls should be inspected, cleaned and oiled. The controls should be checked to see that they fully open but not over travel the internal valve operating lever and operate freely to close the valve.
4. Standard construction internal valves must be removed if the container is to be steam cleaned. Heat can damage the valve's seats and seals.
5. Standard construction internal valves are not designed for water service. Immediately after a container is hydrostatically tested, remove all water and allow the container to thoroughly dry out.

Parts Ordering

Important

Use only genuine MEC replacement parts. Components that are not supplied by MEC should not, under any circumstances, be used in any MEC valve, because they might adversely affect the performance of the valve, and could give rise to personal injury and property damage.

When corresponding about this equipment, always reference the equipment model or series number found on the nameplate.

Valve	ME990S-2F-16	ME990S-2DFM
Available Service Kit		ME990-16-SRK
		ME990-16-VRK
		ME990-PGA
		ME990-PRK

SRK – Seal Repair Kit

VRK – Valve Repair Kit

PGA – Packing Gland Assembly

PRK – Packing Repair Kit

See parts list for corresponding parts and service kit components.

ME990S-2F-16 and ME990S-2DFM

Parts List For ME990S-2F-16			ME990-			
Ref.#	Description	Qty.	16-SRK	16-VRK	PGA	PRK
1	Body, Carbon Steel	1				
2	Stem	1		✓		
3	Valve Poppet	1		✓		
4	Ex. Flow Spring, Yellow, 110 GPM	1				
	Ex. Flow Spring, Green, 160 GPM					
	Ex. Flow Spring, Blue, 260 GPM					
5	Main Valve Seal	1	✓	✓		
6	Seal Retainer	1		✓		
7	Guide Bushing	1	✓	✓		
8	Guide, Plated Steel	1		✓		
9	Spring Seat	1		✓		
10	Closing Spring	1		✓		
11	Valve Poppet Screw	4		✓		
12	Bleed Disc, Nitrile	1	✓	✓		
13	Lock Nut	1		✓		
14	Cotter Pin	1		✓		
15	Gland O-Ring, Nitrile	1	✓	✓	✓	✓
16	Upper Washer	1		✓		
17	Lower Washer	1		✓		
18	Nameplate	1				
19	Name Plate Cap Screw	2				
20	Lever	1				
21	Cotter Pin / Valve Link	1		✓		
22	Gland Assembly, Nitrile	1		✓	✓	
22A	Stub	1				
22B	Bonnet	1				
22C	Wiper, Nitrile	1	✓			✓
22D	Gland Bushing	2	✓			✓
22E	Nylon Washer	1	✓			✓
22F	Female Adapter	1	✓			✓
22G	V-Pack	3	✓			✓
22H	Male Adapter	1	✓			✓
22J	Thick Washer	1				
22K	Gland Spring	1				
22L	Thin Washer	1				
22M	Gland	1				
22N	Spring Pin	1	✓			✓
22P	O-Ring, Nitrile	1	✓			✓
22Q	Cam	1				
22R	Rivet	1				
22S	Roller Bushing	1				
22T	Roller	1				
23	1/4" NPT Plug	1				
24	Fusible Link	1				
25	1 1/4" Steel (Key) Ring	1				
26	Stem O-Ring, Nitrile	1	✓	✓		
27	Flange Gasket	1				
28	Bushing	8				
29	Nut	8				
30	Flange Stud	8				

✓ - Included in service kit

ME990S-2F-16 and ME990S-2DFM

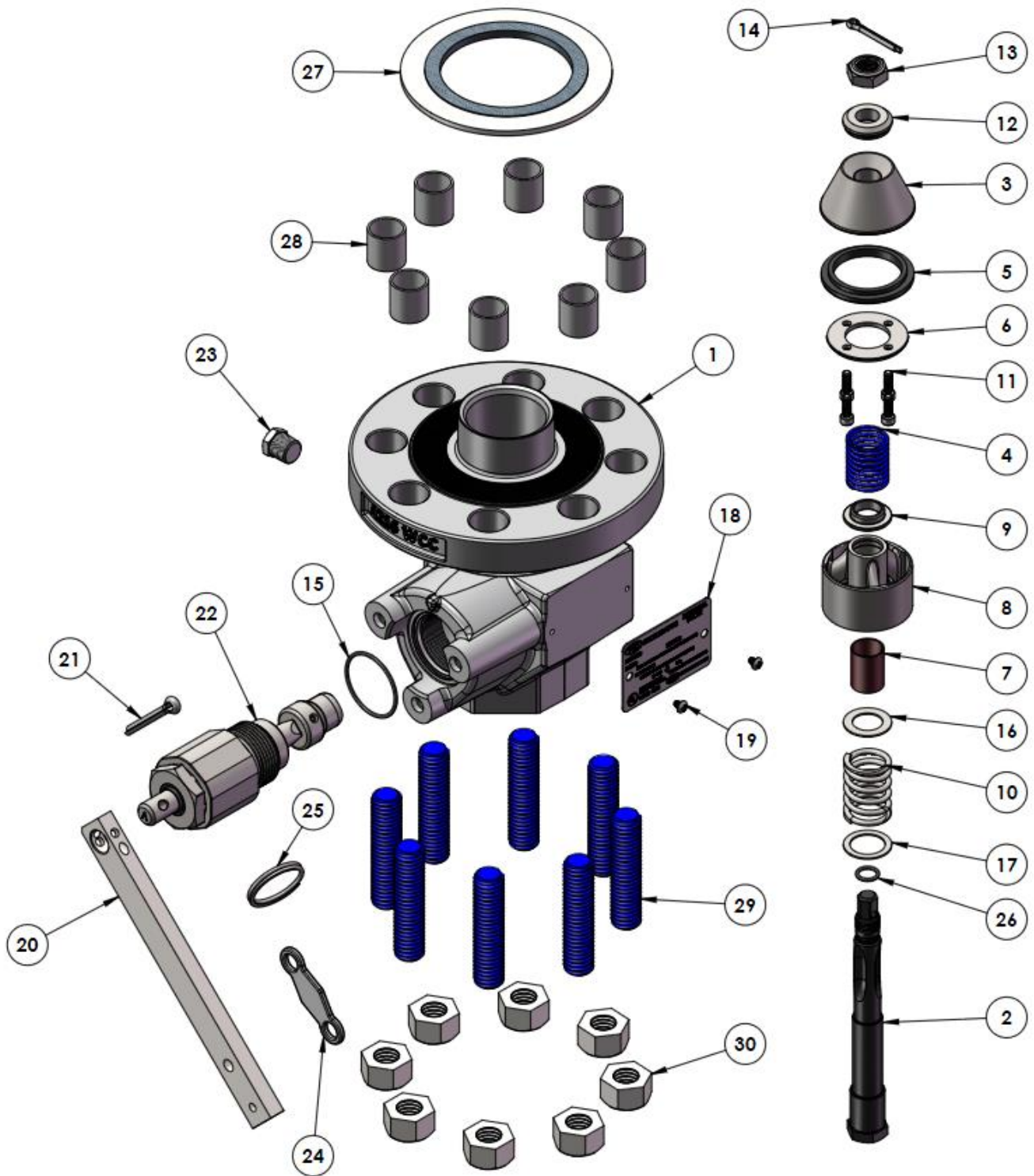

ME990S-2F-16

ME990S-2F-16 and ME990S-2DFM

Parts List For ME990S-2DFM			ME990-			
Ref.#	Description	Qty.	16-SRK	16-VRK	PGA	PRK
1	Body, Carbon Steel	1				
2	Stem	1		✓		
3	Valve Poppet	1		✓		
4	Ex. Flow Spring, Yellow, 110 GPM	1				
	Ex. Flow Spring, Green, 160 GPM					
	Ex. Flow Spring, Blue, 260 GPM					
5	Main Valve Seal	1	✓	✓		
6	Seal Retainer	1		✓		
7	Guide Bushing	1	✓	✓		
8	Guide, Plated Steel	1		✓		
9	Spring Seat	1		✓		
10	Closing Spring	1		✓		
11	Valve Poppet Screw	4		✓		
12	Bleed Disc, Nitrile	1	✓	✓		
13	Lock Nut	1		✓		
14	Cotter Pin	1		✓		
15	Gland O-Ring, Nitrile	1	✓	✓	✓	✓
16	Upper Washer	1		✓		
17	Lower Washer	1		✓		
18	Stem O-Ring, Nitrile	1	✓	✓		
19	1/4" NPT Plug	1				
20	Name Plate Cap Screw	2				
21	Nameplate	1				
22	Gland Assembly, Nitrile	1		✓	✓	
22A	Stub	1				
22B	Bonnet	1				
22C	Wiper, Nitrile	1	✓			✓
22D	Gland Bushing	2	✓			✓
22E	Nylon Washer	1	✓			✓
22F	Female Adapter	1	✓			✓
22G	V-Pack	3	✓			✓
22H	Male Adapter	1	✓			✓
22J	Thick Washer	1				
22K	Gland Spring	1				
22L	Thin Washer	1				
22M	Gland	1				
22N	Spring Pin	1	✓			✓
22P	O-Ring, Nitrile	1	✓			✓
22Q	Cam	1				
22R	Rivet	1				
22S	Roller Bushing	1				
22T	Roller	1				
23	Lever	1				
24	Cotter Pin / Valve Link	1		✓		
25	Flange Gasket	2				
26	Bushing	8				
27	Nut	16				
28	Flange Stud	16				

✓ - Included in service kit

ME990S-2F-16 and ME990S-2DFM

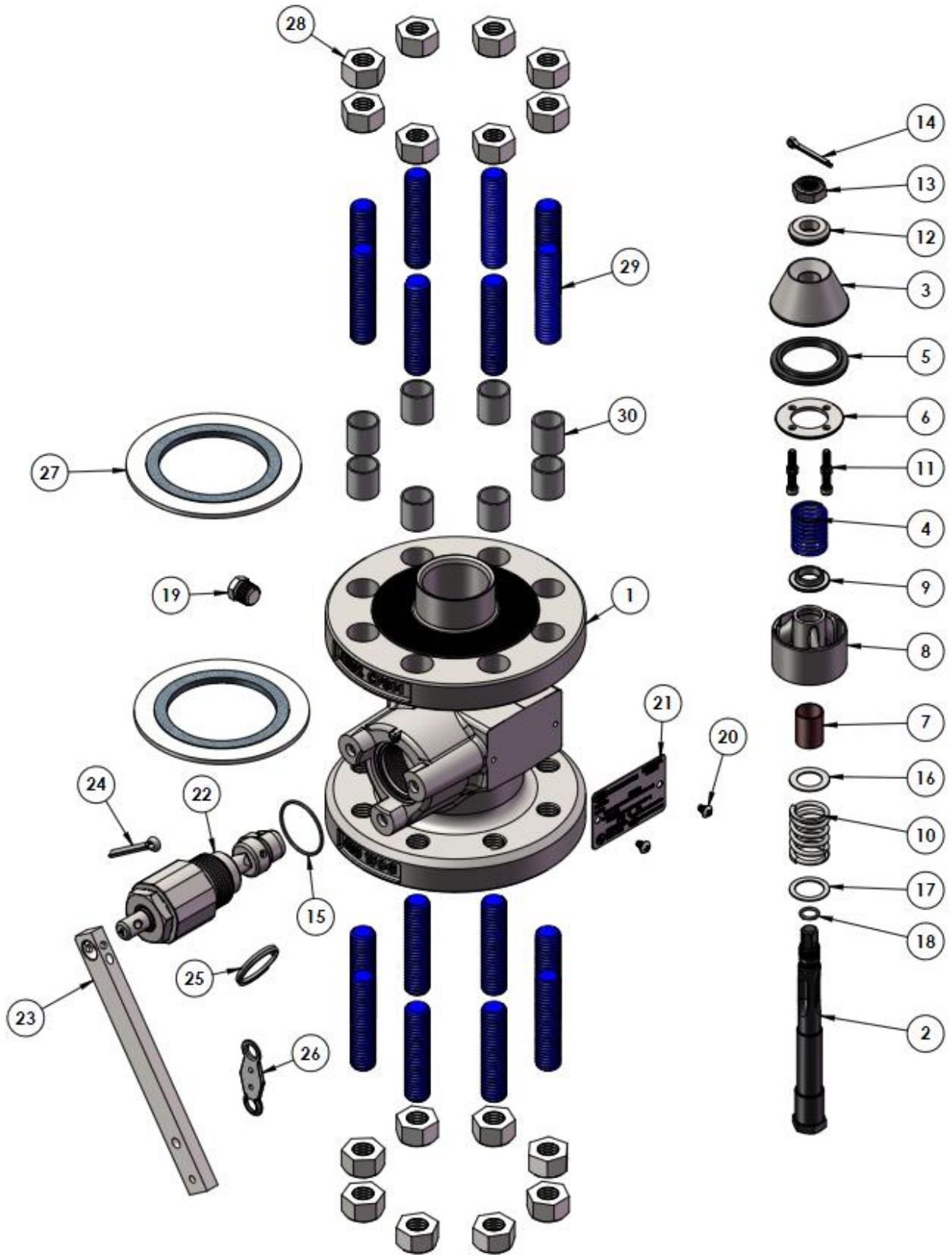

ME990S-2DFM

ME990S-2F-16 and ME990S-2DFM

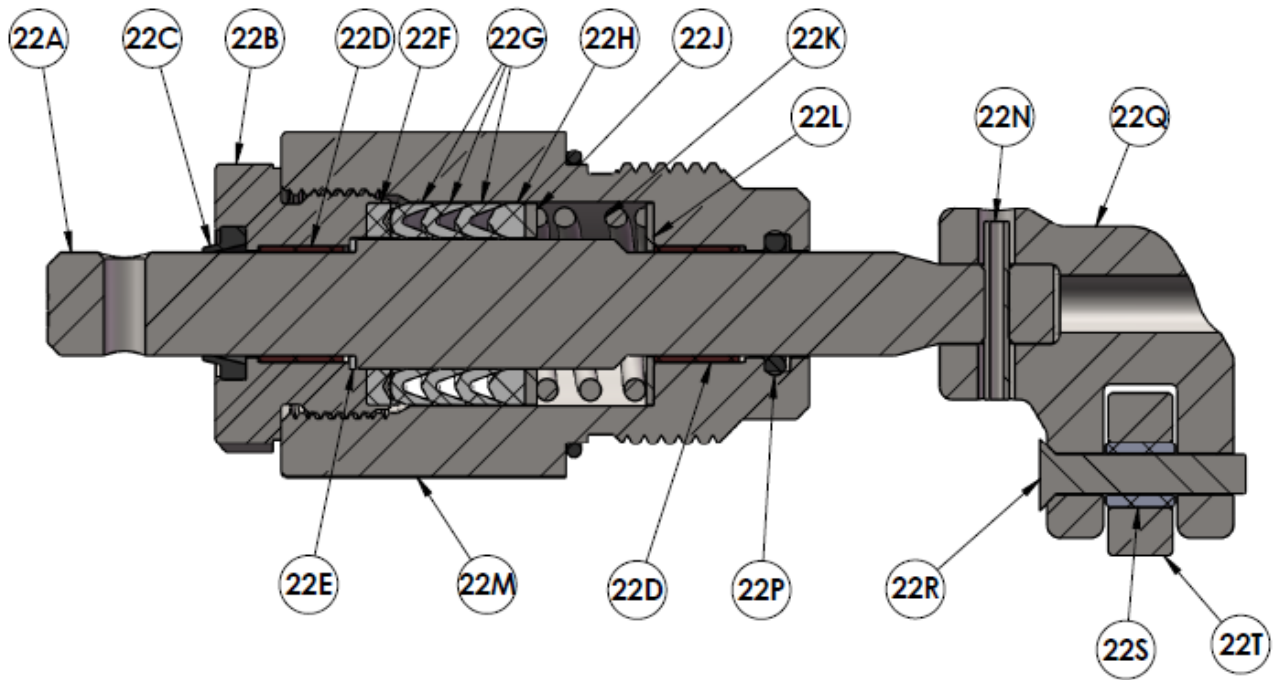

Gland Assembly