



ME228 POWERTORQ SERIES ACTUATOR INSTRUCTION MANUAL

!WARNING!

Failure to follow these instructions or to properly install and maintain this equipment could result in an explosion and/or fire causing property damage and personal injury or death.

Install, operate and maintain Marshall Excelsior Co. equipment in accordance with federal, state, and local codes and these instructions. The installation in most states must also comply with NFPA No. 58, and ANSI/CGA G-2.1.

For installation in the European Union, the equipment must also comply with PED/TPED and EN ISO standards. Periodic inspections, intermediate inspections and exceptional checks of transportable pressure equipment should be carried out in accordance with the Annexes of Directive 2008/68/EC and with 2010/35/EU Directive (TPED) to ensure continued compliance with their safety requirements.

Only personnel trained in the proper procedures, codes, standards and regulations of the LP-Gas Industry should install, maintain and service this equipment.

Be sure all instructions are read and understood before installation, operation and maintenance. These instructions must be passed along to the end user of the product.



WARNING: These products contain a chemical known to the state of California to cause cancer and birth defects or reproductive harm

Introduction

Scope of the Manual

This manual covers instructions for the ME228 Pneumatic Actuator kit.

Description

The ME228 Marshall Excelsior Co. Pneumatic Actuator kit fits the MEC™ (Fisher®) 4" Single flange internal valve to allow for remote valve operation utilizing air pressure. Applying air pressure to the actuator moves the drive coupling and the internal valve shaft to open the valve. Upon loss of air pressure, the valve's operating lever immediately returns to the closed position.

ME228 – For ME990-4F (Fisher® C404) internal valve (4" Single flange)

This kit features a spring return design that eliminates the need for an air return.

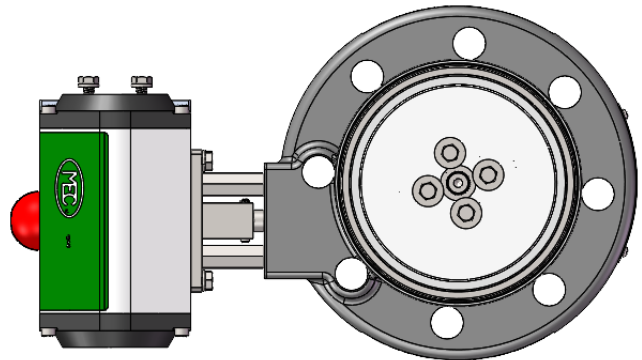
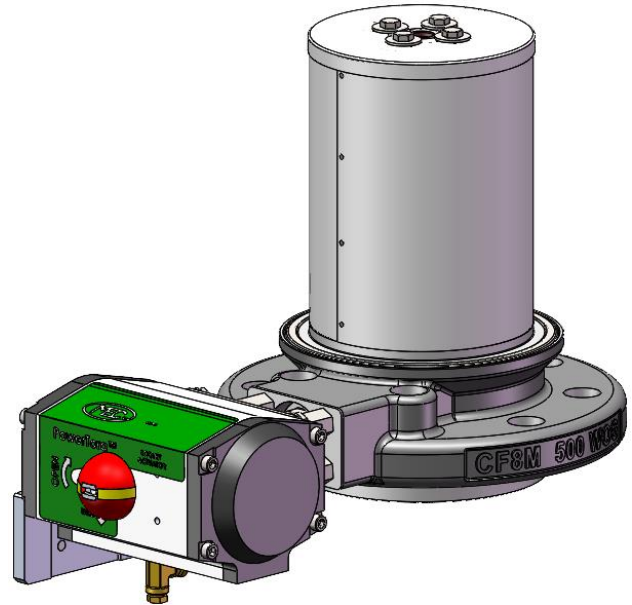

ME990AR-4F

Specifications

Pressure Source:	Air
Pressure Limits:	Minimum – 80 psig / 551 kPa Maximum – 125 psig / 861 kPa Recommended – 100-125 psig / 689-861 kPa
Temperature Limits:	-60°F to 250°F / -51°C to 121°C
Return Mechanism:	Spring only – no air

Installation

!CAUTION!

Do not manually stroke the cylinder. Only operate through the use of Air/Gas pressure.

The use of a pressure reducing regulator to supply the minimum cylinder operating pressure (100-125 psig / 689-861 kPa) to the actuator will maximize cylinder and valve life and minimize air consumption.

Marshall Excelsior Company
1506 George Brown Drive, Marshall, MI, 49068
Phone (269) 789-6700, Fax (269) 781-8340
www.marshallexcelsior.com

MEC Europe AsP
Alsvej 21
8940 Randers SV
Denmark

The contents of this publication are for informational purposes only. While every effort has been made to ensure accuracy, these contents are not to be construed as warranties or guarantees, expressed or implied, regarding the products or services described herein or for their use or applicability. Marshall Excelsior Co. reserves the right to modify or improve the designs or specifications of such products at any time without notice. The MEC™ logo is the trademark of Marshall Excelsior Co.

- To install an actuator kit, first remove any existing operating lever from the internal valve shaft.

!WARNING!

Release all downstream pressure before removing the two screws holding the cover plate to the internal valve body. Failure to follow these instructions or to properly install and maintain this equipment could result in an explosion and/or fire causing property damage and personal injury or death.

- When installing the actuator, first install the drive coupling [1] over the internal valve shaft with the coupling cross hole toward the valve. Align the drive with the internal valve shaft and pin in place with the lock pin [2]. Install E-clip [3] into the opposite side of the lock pin [2] to retain it.



- Remove the screws holding the cover plate to the internal valve body, discard the screws and retain the cover plate. Ensure that the internal valve packing rings remain in position during disassembly and reassembly. With the cover plate in position, install stand-offs [4] through cover plate and hand tighten.
- Position actuator mounting plate [5] over stand-offs [4] with counter-sunk holes facing out. Install mounting screws [6] through mounting plate [5] and hand tighten to stand-offs [4]. Wrench tighten stand-offs [4] to internal valve then wrench tighten mounting plate [5] to the stand-offs [4]. Ensure even gap between cover plate and internal valve packing.
- Rotate drive coupling [1] clockwise by hand until it stops.
- Position actuator with air inlet connection facing away from container and install over drive coupling. Rotate drive coupling [1] counterclockwise up to 1/8 turn (45°), until it engages with the 8-point female input coupling of the actuator. Install mounting bolts [7] with lock washers [8] through mounting plate [5] and wrench tighten to actuator.

Note: The inlet tee connection is factory installed and includes a thermal safety plug which is required by code. This must remain installed to the actuator.

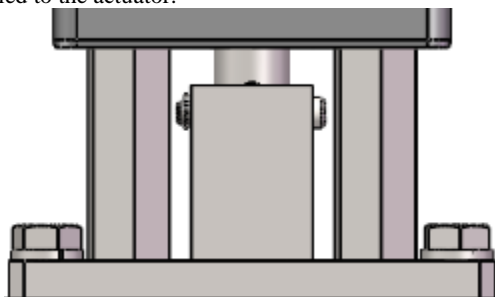

- Connect the actuator pressure line tubing to the inlet port. After installing the unit, operate the actuator with pressure to confirm it smoothly opens and closes the internal valve without sticking or jamming. Confirm actuator opens the valve a full 90 degrees by watching the indicator arrow.

Note: Indicator is rounded to prevent manual operation of actuator.

Maintenance

A simple preventive maintenance program for the valve and its controls will eliminate many potential problems.

Marshall Excelsior Co. recommends these steps be conducted at least once a month:

- Confirm the actuator fully opens and closes the internal valve without sticking. Keep the actuator’s drive coupling free of any build-up of mud, corrosion, or other foreign material. Such a build-up could prevent the actuator from closing which could jam the internal valve in the open position. Do not permit this condition to occur.
- Because the actuator has a sealed housing, internal lubrication is not required. Periodically lubricate the operating coupling joint.
- Regularly inspect, clean and oil all operating controls.

Component List

- Drive Coupling
- Lock Pin
- E-clip
- Stand-offs, Qty: 4
- Mounting Plate
- Mounting Screws, Qty: 4
- Mounting Bolts, Qty: 4
- Lock Washers, Qty: 4

