



# ME208SF PNEUMATIC ACTUATOR INSTRUCTION MANUAL

## !WARNING!

Failure to follow these instructions or to properly install and maintain this equipment could result in an explosion and/or fire causing property damage and personal injury or death.

Install, operate and maintain Marshall Excelsior Co. equipment in accordance with federal, state, and local codes and these instructions. The installation in most states must also comply with NFPA No. 58, and ANSI/CGA G-2.1.

For installation in the European Union, the equipment must also comply with PED/TPED and EN ISO standards. Periodic inspections, intermediate inspections and exceptional checks of transportable pressure equipment should be carried out in accordance with the Annexes of Directive 2008/68/EC and with 2010/35/EU Directive (TPED) to ensure continued compliance with their safety requirements.

Only personnel trained in the proper procedures, codes, standards and regulations of the LP-Gas Industry should install, maintain and service this equipment.

Be sure all instructions are read and understood before installation, operation and maintenance. These instructions must be passed along to the end user of the product.



**WARNING:** These products contain a chemical known to the state of California to cause cancer and birth defects or reproductive harm

## Introduction

### Scope of the Manual

This manual covers instructions for the ME208SF Pneumatic Actuator kit. This kit allows for remote operation of the ME990- 4F (Fisher® C404-32 and C484-32) internal valve.

### Description

The Marshall Excelsior Co. ME208SF Pneumatic Actuator kit fits the ME990-4F (Fisher® C404-32 and C484-32) 4" flanged internal valve to allow for remote valve operation utilizing air pressure.

Applying air pressure to the cylinder moves the cylinder rod and the internal valve's operating lever to open the valve. Upon loss of air pressure, the valve's operating lever immediately returns to the closed position.

This kit features a spring return design that eliminates the need for an air return.

### Specifications

<b>Pressure Source:</b>	Air
<b>Pressure Limits:</b>	Minimum – 20 psig / 138 kPa Maximum – 125 psig / 861 kPa Recommended – 20-25 psig / 138-172 kPa
<b>Temperature Limits:</b>	-60° to 250° F / -51° to 121° C
<b>Return Mechanism:</b>	Spring only – no air

**Marshall Excelsior Company**  
1506 George Brown Drive, Marshall, MI, 49068  
Phone (269) 789-6700, Fax (269) 781-8340  
[www.marshallexcelsior.com](http://www.marshallexcelsior.com)

**MEC Europe AsP**  
Alsvej 21  
8940 Randers SV  
Denmark

The contents of this publication are for informational purposes only. While every effort has been made to ensure accuracy, these contents are not to be construed as warranties or guarantees, expressed or implied, regarding the products or services described herein or for their use or applicability. Marshall Excelsior Co. reserves the right to modify or improve the designs or specifications of such products at any time without notice. The MEC™ logo is the trademark of Marshall Excelsior Co.



## Installation

### !CAUTION!

Do not manually stroke the cylinder.

The use of a pressure reducing regulator to supply the minimum cylinder operating pressure (20-25 psig / 138-172 kPa) to the actuator will maximize cylinder and valve life and minimize air consumption.

1. To install an actuator kit, first remove any existing operating lever from the internal valve shaft.

### !WARNING!

2. **For Fisher valves only:** When installing the ME208SF actuator onto a Fisher® C404-32 or C484-32, release all downstream pressure before removing the four bolts [4] holding the packing retainer plate to the internal valve body. Failure to follow these instructions or to properly install and maintain this equipment could result in an explosion and/or fire causing property damage and personal injury or death.
3. Assemble the Shaft Spline [2] and Shaft Spline Spring Pin [3] onto the internal Valve Shaft as shown below. **For Fisher valves only:** Remove the four bolts from the internal valve shaft area. Leave the packing retainer plate in place and discard the bolts.

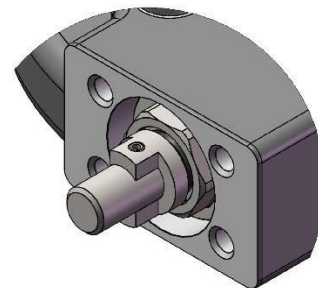

## ME208SF

4. Pre-position the Linkage [5] in the hole of the Bracket [1] and simultaneously position both parts onto the internal valve shaft. Confirm the Linkage [5] mates with the Shaft Spline [2] already assembled on the internal valve shaft.
5. Install the (4) 3/8-16 x 1 1/4" Bolts [4] included with the ME208SF kit through the bracket (and internal valve packing retainer plate noted in the step 2 if installed on Fisher internal valve).
6. Remove the Cotter Pin [8] from the Clevis Pin [6] and Clevis Pin [6] from the Clevis [7]. Rotate the Linkage [5] forward on internal valve shaft.
7. **IMPORTANT** - To assure optimum flow and to prevent damage to the internal valve Shaft Spring Pin [3] by over-traveling the hard stop, the actuator clevis **MUST** be positioned correctly on the actuator. Verify that it is adjusted to the dimension shown below. If adjustment is required, loosen the clevis jam nut [10] on the cylinder rod [11] and adjust the clevis [7] to the dimension shown below. Tighten the Jam Nut [10] securely against the clevis [7].

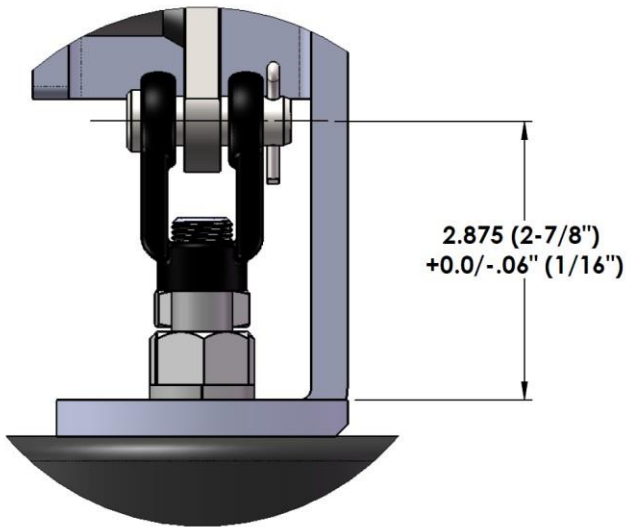

8. Position the Clevis Pin [6] through the Clevis [7] and Linkage [5]. Secure the Clevis Pin [6] with the Cotter Pin [8]. Install and tighten the Linkage Retainer, torque to 35 ft-lb [9] into the side of the bracket to retain the Linkage [5] in position on the shaft and Shaft Spline [2]. Install e-clip [13].
9. Connect the actuating pressure line tubing to the Swivel Connector [12]. After installing the actuator unit, operate the cylinder with pressure to verify it smoothly opens and completely closes the internal valve without sticking or jamming.

### Maintenance

A simple preventive maintenance program for the valve and controls will eliminate many potential problems.

Marshall Excelsior Co. recommends these steps be conducted at least once a month:

1. Inspect the operating lever to see that it opens freely.
2. Confirm the actuator fully opens and closes the internal valve without sticking. Keep the actuator's drive coupling free of any build-up of mud, corrosion, or other

foreign material. Such a build-up could prevent the actuator from closing which could jam the internal valve in the open position. Do not permit this condition to occur.

3. Because the actuator has a diaphragm seal, internal lubrication is not required. For smooth operation, lubricate the linkage / clevis pivot point.
4. Inspect, clean, and oil all operating controls.

### Component List

1. Bracket
2. Shaft Spline
3. Shaft Spline Spring Pin
4. Bolts, 3/8-16 x 1 1/4", Qty: 4
5. Linkage
6. Clevis Pin
7. Clevis
8. Cotter Pin
9. Linkage Retainer
10. Clevis Jam Nut
11. Cylinder Rod
12. Swivel Connector
13. E-Clip

