

**ME800-USRK
 UPPER SEAL REPAIR KIT**

!!!WARNING!!!

READ AND UNDERSTAND ALL INSTRUCTIONS INCLUDED WITH THIS REPAIR KIT
 RELIEVE ALL PRESSURE FROM SYSTEM BEFORE REMOVING VALVE FOR SERVICE

NOTE: Numbers in brackets [] refer to the number in the valve component list.

A. Disassembly

1. **EVACUATE ALL PRESSURE FROM SYSTEM BEFORE ANY DISASSEMBLY OR REPAIR.**
2. Remove Stem Toggle Pin [8], Handle [7], and Thrust Washer [6]. Discard Stem Toggle Pin [8] and Thrust Washer [6].
3. Remove Bonnet [2] and Bonnet Seal [3]. Discard Bonnet Seal [3].
4. Remove Bonnet O-Ring [5] and discard.
5. Remove Stem Assembly [4] and retain.
6. Remove (2) Stem Bushing Nest [9], Stem Bushing [10] and Stem Washer [11] and discard.
7. Inspect Body [1] and Bonnet [2] and clean if necessary, be sure interior is free of dirt, residue, and foreign particles.

B. Reassembly

1. Install Stem Assembly [4] into Body [1].
2. Lubricate and install Bonnet O-Ring [5] into Bonnet [2].
3. Install Bonnet Seal [3] onto Body [1].
4. Apply thread sealant to Bonnet [2] threads and install into Body [1] taking care not to dislodge Bonnet O-Ring [5] from Bonnet [2]. Tighten with minimum of 100 Ft Lbs. of torque.
5. Install Thrust Washer [6] onto top of Bonnet [2].
6. Install Handle [7] onto top of Stem Assembly [4].
7. Install Stem Toggle Pin [8] into Handle [7].
8. Connect the valve assembly outlet to a pressure source of at least 150 PSI. Check for leaks at all joints using a suitable leak detector solution such as “Marshall Excelsior” leak detector.

CAUTION: DO NOT USE THE VALVE IF ANY JOINT CONTINUES TO LEAK UNDER PRESSURE.

C. Component List

1. Body
2. Bonnet
3. Bonnet Seal
4. Stem Assembly
5. Bonnet O-Ring
6. Thrust Washer
7. Handle
8. Stem Toggle Pin
9. Stem Bushing Nest
10. Stem Bushing
11. Stem Washer



WARNING: These products contain a chemical known to the state of California to cause cancer and birth defects or reproductive harm

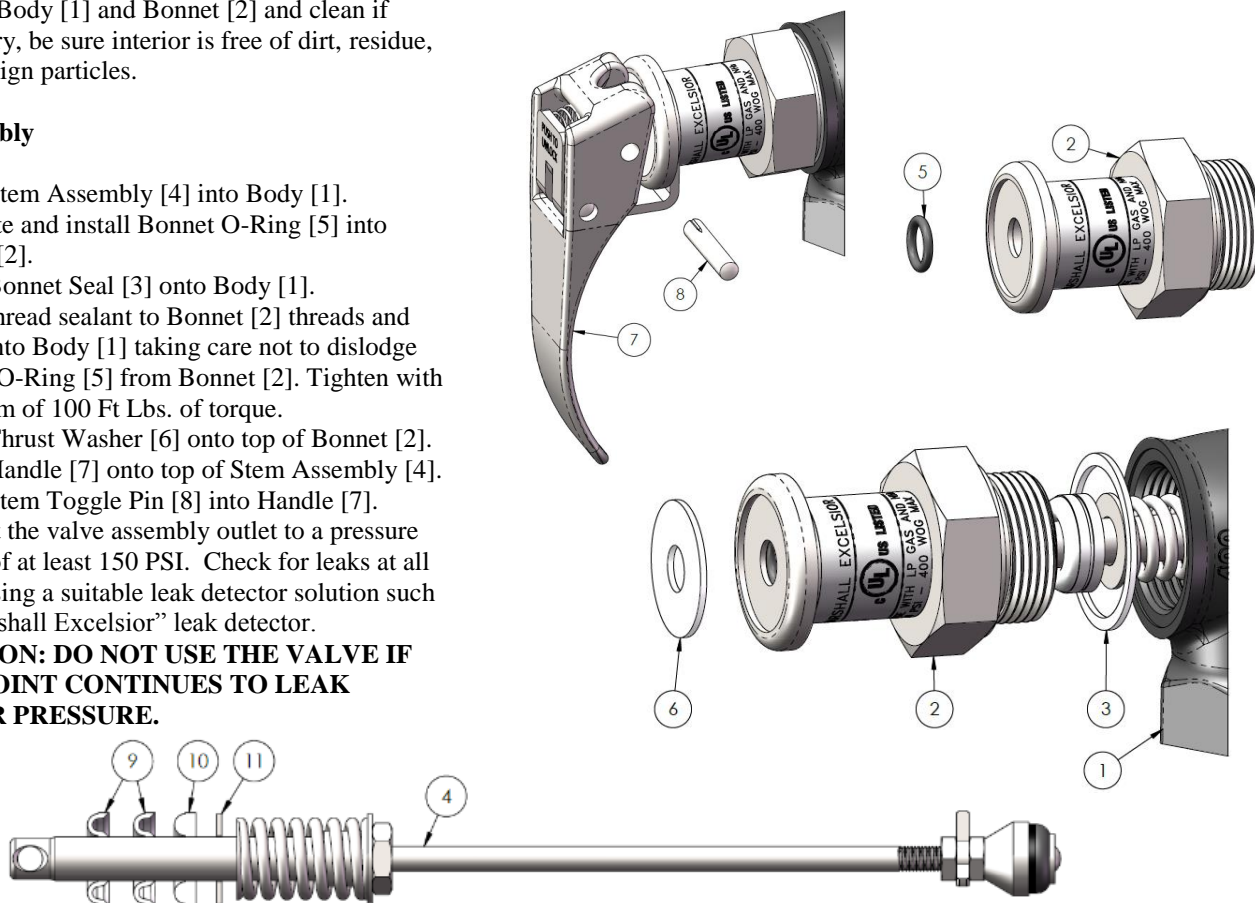

Marshall Excelsior Company

1506 George Brown Drive Marshall, MI 49068
 Phone (269) 789-6700 Fax (269) 781-8340
 www.marshallexcelsior.com

The contents of this publication are for informational purposes only. While every effort has been made to ensure accuracy, these contents are not to be construed as warranties or guarantees, expressed or implied, regarding the products or services described herein or for their use or applicability. Marshall Excelsior Co. reserves the right to modify or improve the designs or specifications of such products at any time without notice. The MEC™ logo is the trademark of Marshall Excelsior Co.