

NOTE: Numbers in brackets [] refer to the number in the valve component list. Numbers in parenthesis () refer to quantities of the valve component.

!WARNING!

Failure to follow these instructions or to properly install and maintain this equipment could result in an explosion and/or fire causing property damage and personal injury or death.

Install, operate and maintain Marshall Excelsior Co. equipment in accordance with federal, state, and local codes and these instructions. The installation in most states must also comply with NFPA standards 58 and 59, ANSI/CGA G-2.1, and DOT standards.

For installation in the European Union, the equipment must also comply with PED/TPED and EN ISO standards. Periodic inspections, intermediate inspections and exceptional checks of transportable pressure equipment should be carried out in accordance with the Annexes of Directive 2008/68/EC and with 2010/35/EU Directive (TPED) to ensure continued compliance with their safety requirements.

Proper installation of remote actuation devices should include thermal protection to close the internal valve in case of a fire. This pneumatic actuator includes thermal protection.

Only personnel trained in the proper procedures, codes, standards, and regulations of the LP Gas or anhydrous ammonia (NH3) industries should install and service this equipment.



WARNING: These products contain a chemical known to the state of California to cause cancer and birth defects or reproductive harm

Introduction

Scope of the Manual

This manual covers instructions for the ME206, ME207, and ME207SF Pneumatic Actuator kits. These kits allow for remote operation of 2" and 3" MEC and Fisher® internal valves.

Description

The Marshall Excelsior Co. (MEC) Pneumatic Actuators are designed to fit 2" and 3" internal valves to allow for remote operation utilizing air or nitrogen pressure. Applying air pressure to the actuator moves the main actuator shaft to rotate the internal valve shaft and open the valve. Upon loss of air pressure, the valve's operating lever immediately returns to the closed position.

This kit features a spring return design that eliminates the need for an air return.

!CAUTION!

Interior components of pneumatic actuators are not compatible with LPG. Only use air or nitrogen to pressurize actuators.

Marshall Excelsior Company

1506 George Brown Drive Marshall, MI 49068
Phone (269) 789-6700 Fax (269) 781-8340
www.marshallexcelsior.com

Marshall Excelsior Europe LTD

90 Brynteg Road
Gorseinon, Swansea, SA4 4FR - UK
01382-714308

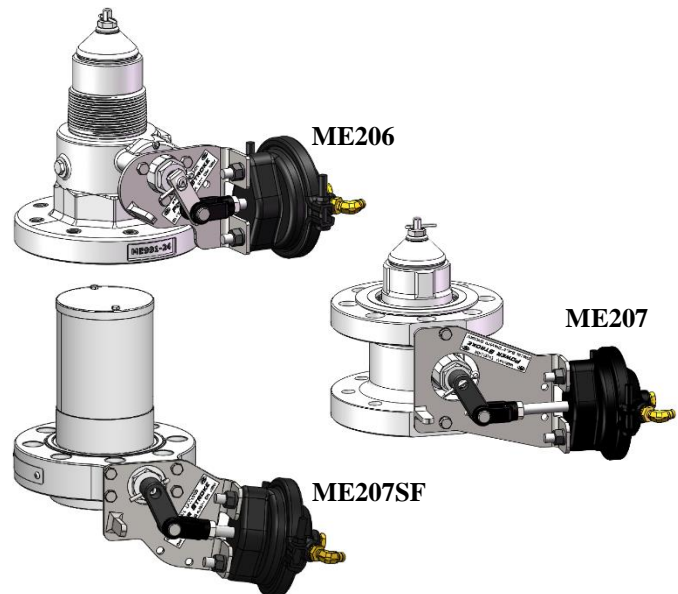

ME206 – For all MEC 2" internal valves, and all 3" internal valves excluding the series supported by ME207 (Fisher® C402, C421, C471, C427, C477)

ME207 – For MEC ME990-3DF, -3DFO, and -3DFM Series double-flanged internal valves (Fisher® C403-24, C483-24)

ME207SF – For ME990-3F Series single-flanged internal valves (Fisher® C404-24)

Specifications

Pressure Source: Air or Nitrogen Gas
Operating Limits: Minimum – 20 psig / 138 Kpa
Maximum – 125 psig / 862 Kpa
Recommended – 20-25 psig / 138-173 Kpa
Temperature Limits: -60°F to 250°F / -51°C to 121°C
Return Mechanism: Spring only – no air

Installation

!CAUTION!

Do not manually stroke the actuator shaft.

The use of a pressure reducing regulator to supply the minimum actuator operating pressure (20-25 psig) to the actuator will maximize actuator and valve life and minimize air consumption.

- To install an actuator kit, first remove any existing operating lever from the internal valve shaft.

!WARNING!

2. **For Fisher Valves Only:** When installing, release all downstream pressure before removing the screws holding the cover plate to the internal valve body. Failure to follow these instructions or to properly install and maintain this equipment could result in an explosion and/or fire causing property damage and personal injury or death.
3. Align Flange [1] against valve so that main actuator body is to the right of the main valve shaft as shown; ensure Valve Linkage [2] is fitted onto main valve shaft during alignment
4. Install provided Mounting Hardware [3] through Flange [1] into threaded holes of valve.
5. Install Cotter Pin [4] through Valve Linkage [2] and internal valve shaft. Bend Cotter Pin to retain.

IMPORTANT - To assure optimum flow and to prevent damage to the internal valve or Cotter Pin [4] by over-traveling the hard stop, the actuator clevis [8] must be positioned correctly on the actuator. See dimensions shown for use with MEC products; correct height may differ when used with non-MEC products.

If adjustment is required:

- a. Loosen Jam Nut [6] on Cylinder Rod [5]; remove Clevis Pin [7] and adjust Clevis [8] to dimension shown.
- b. Tighten the Jam Nut [6] securely against the clevis [8], reinstall Clevis Pin [7] through Clevis [8] and Valve Linkage [2].
6. Connect an actuating pressure tube into Swivel [9].
7. Operate actuator with pressure to confirm the valve opens and closes without sticking or jamming.

Maintenance

A simple preventive maintenance program for the valve and its controls will eliminate many potential problems.

Marshall Excelsior Co. recommends these steps be conducted at least once a month:

1. Confirm the actuator fully opens and closes the internal valve without sticking. Keep Main Shaft [5] free of any build-up of mud, corrosion, or other foreign material. Such a build-up could prevent the actuator from closing which could jam the internal valve in the open position. Do not permit this condition to occur.
2. Because the actuator has a diaphragm seal, internal lubrication is not required. Periodically lubricate the pivot between Main Shaft [5] and Valve Linkage [2].
3. Regularly inspect, clean and oil all operating controls.

Component List

1. Flange
2. Valve Linkage
3. Mounting Hardware

| Item No. | Hardware Description | ME206 Qty | ME207 Qty | ME207SF Qty |
|----------|----------------------|-----------|-----------|-------------|
| 3a | Lock Washer | 3 | 2 | 0 |
| 3b | Socket Head Screw | 3 | 0 | 0 |
| 3c | Hex Screw | 3 | 2 | 4 |

4. Cotter Pin
5. Main Shaft
6. Jam Nut
7. Clevis Pin
8. Clevis
9. Swivel

