



ME1000-10 1-1/4" INTERNAL COMBINATION VALVE INSTALLATION AND OPERATING MANUAL



!WARNING!

Failure to follow these instructions or to properly install and maintain this equipment could result in an explosion and/or fire causing property damage and personal injury or death.

MEC equipment must be installed, operated, and maintained in accordance with federal, state, and local codes and according to the manufacturer's instructions. The installation in most states must also comply with NFPA No. 58, and ANSI/CGA G-2.1.

For installation in the European Union, the equipment must also comply with PED/TPED and EN ISO standards. Periodic inspections, intermediate inspections and exceptional checks of transportable pressure equipment should be carried out in accordance with the Annexes of Directive 2008/68/EC and with 2010/35/EU Directive (TPED) to ensure continued compliance with their safety requirements.

Only personnel trained in the proper procedures, codes, standards, and regulations of the LP-Gas or Anhydrous Ammonia industries should install and service this equipment.

The internal valve must be closed except during product transfer. A line break downstream of a pump may not actuate the excess flow valve. If any break occurs in the system or if the excess flow valve closes, the system should be shut down immediately.

Scope of the Manual

This manual covers instructions for the ME1000-10 "Excelerator" series 1-1/4" threaded internal combination valves and the manual, cable, or pneumatic actuators for the valve.

Introduction

The ME1000-10 Internal Combination Valve unites an internal valve, downstream shut-off valve and filter element of a traditional Y-strainer into a single, compact valve body. The ME1000-10 can be used in liquid or vapor withdrawal in LPG dispensers and NH₃ nurse tanks as well as emergency liquid withdrawal on stationary and mobile tanks. Designed for LP-Gas or NH₃ (Anhydrous Ammonia) at ambient temperatures, the valve can be used on other compressed gases, but the user should check with the factory to make sure the valve is suitable for the particular product.



WARNING: These products contain a chemical known to the state of California to cause cancer and birth defects or reproductive harm

Marshall Excelsior Company

1506 George Brown Drive Marshall, MI 49068
Phone (269) 789-6700 Fax (269) 781-8340
www.marshallexcelsior.com

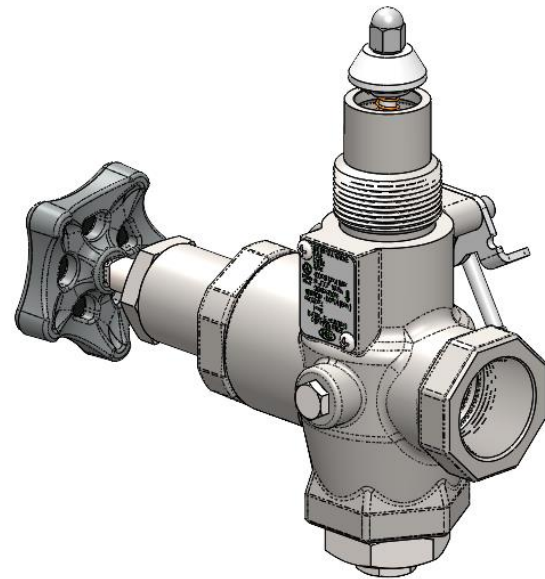

ME1000-10 Product Specific Note

The ME1000-10 combines the features of MEC's Excelerator Internal Valves, Globe Valves, and Y-Strainer. While all aspects of the ME1000-10 work independently from each other, the internal valve will only function as described when the globe valve is fully open and the strainer is clean.

The following are a list of available attachments for the ME1000-10:

ME990-10-902 – Latch/remote release mechanism that permits remote internal valve closure. The valve is opened manually. A built in fusible element will release at 212°F (100°C) allowing the valve to close. Factory part number with the ME990-10-902 latch included is ME1000M-10.

ME1000A-901 – Pneumatic actuator kit. Remotely actuates the internal valve. Factory part number with the ME1000A-901 kit included is ME1000A-10.

ME225 – Rotary pneumatic actuator kit. Remotely actuates the internal valve. Factory part number with the ME225 kit included is ME1000AR-10

Marshall Excelsior Europe LTD

90 Brynteg Road
Gorseinon, Swansea, SA4 4FR - UK
01382-714308

The contents of this publication are for informational purposes only. While every effort has been made to ensure accuracy, these contents are not to be construed as warranties or guarantees, expressed or implied, regarding the products or services described herein or for their use or applicability. Marshall Excelsior Co. reserves the right to modify or improve the designs or specifications of such products at any time without notice. The MEC™ logo is the trademark of Marshall Excelsior Co.

ME1000-10

Features

- **Independent Piloted Shut-off Valve** – Allows side outlet to be sealed.
- **40 Mesh Strainer** – Filters particulates and debris from the side outlet with structural skeleton to protect the shut-off valve against impacts.
- **Excelsior equalization bleed area** – Provides high bleed flow for quick opening.
- **Durable Design:**
 - Stainless poppet and stem with hardened, low friction coating operates smoothly for a long wear life
 - Integral travel stop
 - Stainless steel roller cam
- **Excess Flow Closure** – Functions when flow exceeds the rated capacity of the valve or piping is sheared off at the valve.
- **Back Check Feature** – Allows reverse flow filling with or without actuator device in valve open position, so long as the independent shut-off is open.
- **Spring loaded Polytetrafluoroethylene (PTFE) stub shaft packing**
- **Rulon® bushings at critical wear points.**
- **Manual, Cable, or Air Open/Close valve actuators.**
- **Thermal Fusible links or plugs melt at 212°F (100°C) and allow valve closure in the event of a fire at the valve.**

Specifications

Specifications

Body Size and End Connection Styles:

Inlet: 1-1/4" MNPT
Side Outlet: 1" or 1-1/4" FNPT
Bottom Outlet: 1" or 1-1/4" FNPT

Maximum Allowable Inlet Pressure:

400 psig / 27.6 bar WOG

Excess Flow Springs:

GPM (Vertical down)

1" Outlet: 40, 55, and 70

Lpm: 152, 208, and 265

1-1/4" Outlet: 55, 70, and 90

Lpm: 208, 265, and 340

Temperature Capabilities:

-40° to 150°F / -40° to 66°C

Approximate weight:

9.6 pounds / 4.4 kg

Body Materials:

Stainless Steel

DOT Internal Self-Closing Stop Valve Requirement:

U.S. Department of Transportation (DOT) regulations 49CFR§178.337-8(a)(4) require each liquid or vapor discharge outlet on cargo tanks (except for cargo tanks used to transport chlorine, carbon dioxide, refrigerated liquid, and certain cargo tanks certified prior to January 1, 1995) to be fitted with an internal self-closing stop valve. ME990 series internal valves comply with the internal self-closing stop valve requirement under the DOT regulations.

Installation

Mounting and Piping

The ME1000-10 internal valves can be installed in either a half or full coupling. Excess flow spring closing flow rates vary based on coupling style used, refer to the Specification section.

!CAUTION!

Excess flow valve closing flow rates are not the same for half and full couplings. Verify the coupling for the desired excess flow rate.

Do not install the valve in any piping tending to restrict the valve inlet because this may prevent the excess flow valve from closing.

Do not install the valve with such extreme torque that the coupling can cut threads into the valve. This could cause valve distortion and affect the internal working parts.

Use an appropriate pipe compound on the male threads of the internal valve and pipeline. Install the valve into the coupling hand tight, and then wrench tighten it for approximately two additional turns. Larger size valves may require an additional amount of torque to obtain a leak-free connection.

Keep piping from the valve outlet to the pump full size and as short as possible with a minimum number of bends. Reduction in pipe size to suit smaller pump inlets should be made as close to the pump as possible using forged reducers (swage nipples) or venturi tapers rather than bushings. This assures minimum flow resistance and efficient pump operation.

After installation, check all joints for leaks using a suitable leak detector solution such as Marshall Excelsior low temp leak detector before putting the valve into service.

The valves feature a break off section located below the inlet pipe thread which is intended to permit the lower valve body to shear off in an accident, leaving the valve seat in the tank. **The break off section is designed for container installations and will probably not provide shear protection if the valve is installed in a pipeline.**

A hydrostatic relief valve does not need to be installed adjacent to the valve since the internal valve feature relieves excessive line pressure into the tank.

Selectively Filling Manifolder Tanks

MEC internal valves provide positive shutoff in only one direction, from out of the tank to downstream of the valve. The internal valves are designed to allow gas to flow into a tank when the downstream line pressure exceeds tank pressure. If you want to selectively fill one or more of the other tanks in a tank manifold system, you must close the ME1000's shut-off valve, otherwise, all tanks will be filled at the same time and at about the same rate.

Excess Flow Protection

The internal valve contains an excess flow function, or "integral excess flow valve", that is designed to close when the flow exceeds the flow rating established by MEC. MEC integral excess flow valves installed on a bobtail truck or transport can provide protection against the discharge of hazardous materials during an unloading operation of a bobtail truck or transport in the event that the pump or piping attached directly to the internal valve is sheared off before the first valve, pump, or fitting downstream of the internal valve, provided that the cargo tank pressure produces a flow rate greater than the valve's excess flow rating. Likewise, if the internal valve is installed on a stationary tank or in the related downstream piping system, the integral excess flow valve can provide protection against an unintentional release of hazardous materials in the event that a pump or piping attached directly to the internal valve is sheared off before the first valve, pump, or fitting downstream of the internal valve, provided that the flow of product through the internal valve reaches the rated flow specified by MEC.

!EXPLOSION HAZARD!

Restrictions incorporated in the discharge system of a bobtail truck, transport or a stationary tank, may include but not limited to pumps, pipe and hose length and dimensions, branching, elbows, reductions in pipe diameter, or a number of other inline valves or fittings. Low operating pressure may be a result of ambient temperature, or a partially closed valve downstream from the integral excess flow valve; this can restrict the rate of flow through the internal valve below the level necessary to actuate the integral excess flow valve.

Therefore, **DO NOT USE** the excess flow function of the internal valve for the purpose of providing protection against the discharge of hazardous materials. In the event of a ruptured hose or piping at a point in the discharge system downstream from the first valve, pump or the internal valve, the excess flow feature is designed to close upon a significant increase in differential pressure or flow.

The internal valve is designed with an internal bleed feature for equalization of pressure. After the integral excess flow valve closes, the leakage through the bleed must be controlled or a hazard can be created. For this reason the operator must be familiar with the closure controls for the

internal valve and must close the internal valve immediately after the integral excess flow valve closes.

Failure to follow this warning could result in serious personal injury or property damage from a fire or explosion.

DOT Passive Shutdown Equipment Requirement - DOT regulations 49CFR§173.315(n)(2) require certain cargo tanks transporting propane, anhydrous ammonia and other liquefied compressed gases to be equipped with passive emergency discharge control equipment that will automatically shut-off the flow of product without human intervention within 20 seconds of an unintentional release caused by complete separation of a delivery hose. The design for each passive shutdown system must be certified by a Design Certifying Engineer (DCE) and all components of the discharge system that are integral to the design must be included in the DCE certification. The DCE certification must consider any specifications of the original component manufacturer.

In the case of downstream ruptures in hose or piping, a variety of operating conditions routinely encountered during an unloading operation restrict the rate of flow through the integral excess flow valve and make such a valve unsuitable to serve as the means of passive shutdown required under 49CFR§173.315(n)(2). Such variables include restrictions incorporated in the discharge system (due to pumps, pipe and hose length and dimensions, branching, elbows, reductions in pipe diameter, or a number of other in-line valves or fittings), low operating pressure as a result of ambient temperature, or a partially closed valve downstream from the excess flow valve.

Due to the variety of conditions, in the case of a hose separation, that can restrict the rate of flow below the level necessary to activate the excess flow valve, the integral excess flow function of ME1000 series internal combination valves cannot be used to satisfy the passive shutdown equipment requirement under/in 49CFR§173.315(n)(2).

Also, a Design Certifying Engineer cannot include the integral excess flow valve of a ME1000 series internal combination valve as a component of the discharge system in any DCE certification under 49CFR§173.315(n)(2).

!EXPLOSION HAZARD!

DO NOT USE the excess flow function incorporated into ME1000 series internal combination valves to satisfy the passive shutdown equipment requirement in 49CFR§173.315(n)(2). **DO NOT** include the excess flow function incorporated into ME1000 series internal combination valves in a DCE certification under 49CFR§173.315(n)(2). The cargo tank manufacturer must install some other equipment that satisfies the requirement for passive shutdown capability under 49CFR§173.315(n)(2).

ME1000-10

Failure to follow this warning could result in serious personal injury or property damage from a fire or explosion in the event of an unintentional release of product during an unloading operation.

!WARNING!

If the ME1000-10 valve is installed in a pressurized tank, ensure that the line pressure is 0 psi (0 bar) prior to beginning installation of any latch or actuator.

Actuators

The remote operating control system for the internal valve is extremely important, and it must be installed to conform to the applicable codes. DOT MC331, for example, most generally applies for trucks.

MEC offers both cable controls and pneumatic actuator systems to operate the ME1000-10 internal combination valves. It may also be possible to use cable controls from other manufacturers or to fabricate a linkage mechanism. Any control system requires thermal protection (fuse links) at the valve, at the remote control point and, if necessary, near the hose connections. The instruction manuals for MEC actuator systems show how to install the fuse links.

The operating linkage must allow the operating lever to move from the fully closed position to within 2° of the fully open position. The linkage should not apply strong force to the lever past the fully open position or the valve could be damaged.

Note

The use of non-MEC actuators may result in leakage of the gland packing caused by premature wear. In addition to premature wear, the use of non-MEC actuators may result in lower than expected flow rates and possible leakage across the valve seats.

!CAUTION!

The internal valve's closing spring is not designed to overcome drag in the control linkage in order to close the valve. Depending upon the control system used, an external spring or positive closing linkage may be needed. Be sure the control system is installed to prevent binding that could cause the valve to stick in the open position.

Cable Operation - The operating linkage should stroke the valve operating lever from the fully closed position to within a minimum of 2° of the full open position. Too short an operating lever stroke will result in premature excess flow valve closure. The cable control linkage can be attached through the hole in the operating lever to provide remote valve operation.

Remote Release - To install the ME990-10-902 latch mechanisms, first release the downstream pressure.

Failure to do so could result in personal injury. Remove the operating lever and take off the cover plate by removing the cap screws. The new cover plate/latch assembly can be attached to the valve with the same cap screws. Tighten the screws to 25 to 30-inch-pounds (33.9 to 40.7 N·m) torque.

A cable must be ran from the pull ring on the latch to the release handle. The cable must be taut for proper operation, and the hookup may require sufficient pulleys to keep the cable away from the side of the tank. Pulling the release handle allows the manual operating lever to return to the closed position. The fusible link in the mechanism will melt if exposed to fire, allowing the valve to close.

When closing the valve manually, pull back on the cable attached to the release mechanism to permit the valve lever to close.

ME1000-10

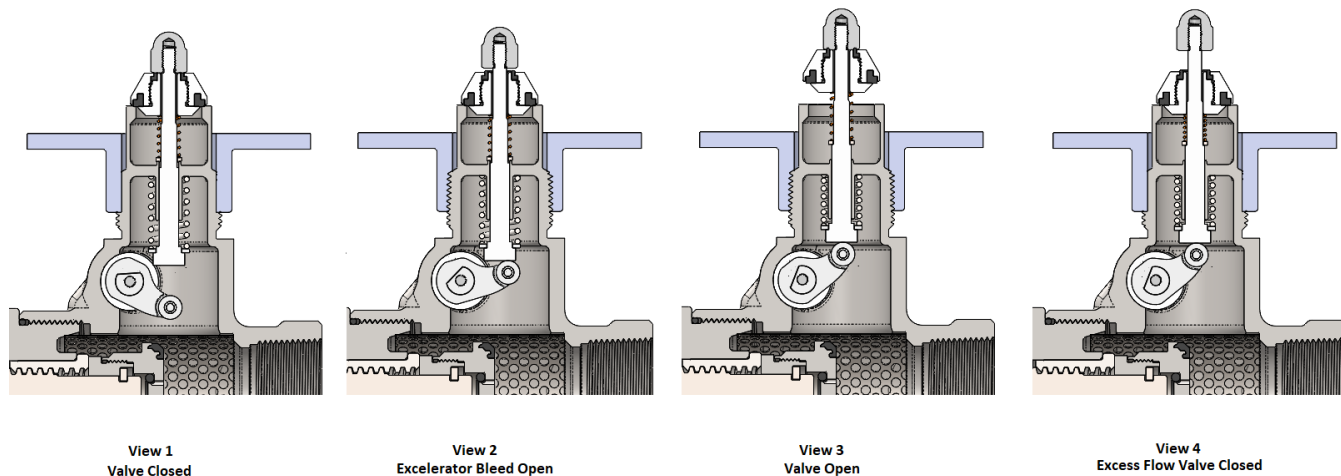

Figure 1: Operational Schematic

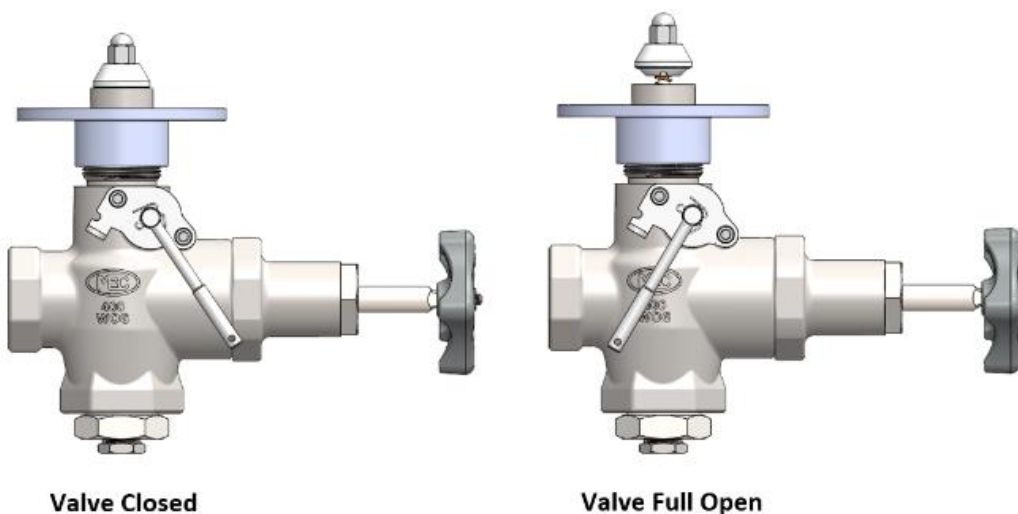

Figure 2: Handle orientation

!WARNING!

Avoid getting in the way of the lever as it moves to the closed position as there is strong spring force on the operating lever. Failure to do so could result in personal injury.

Principle of Operation

Refer to the operational schematic (Figure 1, View 1). The valve is held closed by both tank pressure and the valve's closing spring. There is no leakage past the resilient seals in the poppet to the valve outlet in this position.

The valve is opened by first rotating the Shutoff handle to the full open position (Figure 2), then moving the operating lever to approximately midpoint in its 70° travel (Figure 1, View 2). This allows the cam to place the rapid equalization portion of the valve stem in the pilot opening, permitting a larger amount of product to bleed

downstream than if the operating lever were moved to the full open position.

When tank and downstream pressures have equalized in the bleed position, (after a few seconds), the excess flow spring pushes open the main poppet (Figure 1, View 3) and the operating lever can be moved to the full open position.

If tank pressure is greater than the valve's outlet pressure, the main poppet will remain in the closed position. If valve outlet piping is closed off by other valves, however, product bleeding through the pilot will increase until it nearly equals tank pressure and the main poppet opens.

Note

The main poppet will not open if valve outlet piping is not closed off so that the outlet pressure can approach tank pressure.

Once the main poppet opens, a flow greater than the valve's excess flow spring rating or a sufficient surge in

ME1000-10

flow forces the main poppet closed against the excess flow spring (Figure 1, View 4). The pilot valve allows a small amount of product to bleed, but much less than (Figure 1, View 2) where the rapid equalization portion of the stem is placed in the pilot opening. When the operating lever is moved to the closed position, the valve closes completely and seals tightly (Figure 1, View 1).

Operation

It is important that there is pressure equalization during the operating sequence. The ME1000-10 internal valve will not open unless the downstream pressure can build-up to equal the inlet pressure.

Follow these steps:

1. ME1000-10 on bobtails and transports should never be open when the truck is in motion. If the control system is not interlocked to prevent this, the operator is responsible to ensure that the valves are closed.
2. Always open the internal valve and shut-off valve before opening any other valves in the line or starting the pump.
3. Move the lever to the half-open (rapid equalization) position (Operational Schematic Figure 1, View #2) to equalize pressure. When the main poppet clicks open, move the operating lever fully open.
4. Open other line valves slowly to avoid sudden surges which could slug the excess flow valve shut.
5. If the excess flow valve does close, stop the pump and close shut-off valve. Move the internal valve's operating lever back to the rapid equalizing position (outlined in step 3) and wait for the valve to click open. Then move the operating lever fully open and slowly open the downstream valve.
6. All valves should be completely open when pumping. **(Throttling type valves could prevent the excess flow valve from closing when required.)**
7. The operator must always be aware of where the remote closure controls are located and know how to operate the controls if an emergency requires valve closure. When pumping is finished, make a habit of closing the internal valve from the remote closure point, thus checking to see that the control actually is capable of closing the valve and operating correctly.
8. The valve should be open when backfilling through the valve to fill the tank.

Troubleshooting

Internal Valve Will Not Open: This could be due to leakage downstream, engaging the pump too soon or from excessive wear in the internal valve. If excessive volume is in the downstream system, a longer time is required to equalize the pressures (tank and downstream) before the pump can be engaged. To determine if the valve pilot seat is opening, install a gauge downstream of the valve, operate the valve actuator; if pressure does not build up to the tank pressure, the valve pilot seat is not open. This test should be done with the pump off. If the pilot is not opening, it may be plugged with dirt or some internal part

may be broken. If by operating the lever manually it can be rotated past the fully open position, there is something wrong internally and the valve must be disassembled.

Premature Internal Valve Closure: This can be caused from engaging the pump too soon, by an underrated excess flow valve spring, or by an improperly connected internal valve operating lever which does not fully open the valve. The trouble could also be from a valve that has its inlet port obstructed or from sudden line surges. In order to check the valve opening travel, operate the lever manually to the full travel, wait until valve opens (usually about 15 seconds), then engage the pump. If the excess flow closes, the points mentioned above should be investigated.

Internal Valve Will Not Close: Ensure the shut-off valve is fully open. The stub shaft could be binding or the stem could be bent in the valve. Before disassembling the valve, check the actuator mechanism to see that it operates freely by disconnecting it from the valve lever and cycling it several times. Also, operate the valve lever manually. If it sticks in the open position, the packing and bushings should be replaced. This should free the operating mechanism if the valve has not been damaged internally. Refer to the "Maintenance" section.

Low Flow Capacity: First, ensure the shut-off valve is fully open. This could be caused by an undersized internal valve, undersized or long downstream piping, a plugged or dirty strainer, some other restriction in the downstream system, or by the bypass valve sticking in the open position. The bypass valve could also be set too low and be opening prematurely.

!CAUTION!

Do not use these internal valves if they leak, fail to work properly or have been damaged or have missing parts. Prompt repairs should be made by a properly trained serviceman. Continued use without repair can create a hazardous situation which could result in serious or fatal personal injury or property damage.

ME1000-10

Maintenance

A simple preventative maintenance program for the valve and its controls will eliminate many potential problems.

MEC recommends these steps be conducted once a month. Also refer to the Department of Transportation (DOT) CFR49 Sections 180.416 and 180 Appendix A and B which specify monthly maintenance and inspection tests for cargo tank service internal valves and their actuation controls.

1. Regularly inspect the operating lever to see that it operates freely and that there is no leakage around the stub shaft. If there is leakage or sticking, the packing should be replaced using ME990-10-SRK or ME990-10-PGA.
2. Check for tight closure of the valve seal. Any detected leakage, which is normally caused by seal wear or dirt, scale or debris embedded in the seal, requires that the internal valve be removed from service and repaired. Repair most often requires the replacement of valve seals. To check for leakage:
 - a. Close the internal valve and exhaust downstream pressure. Close the first valve downstream from the internal valve, and note any pressure buildup, using a pressure gauge, between the closed valve and the internal valve. If piping is cold, allow it to warm to ambient temperature.
 - b. Refer to CFR 49 Section 180 Appendix B for Meter Creep Test Methods.
3. All operating controls should be inspected, cleaned and oiled. The controls should be checked to see that they fully open but not over travel the internal valve operating lever and operate freely to close the valve.
4. The valves strainer should be flushed at regular intervals. One outlet of the valve has a ½" NPT port that can be unplugged to serve as a blowout path.
5. Standard construction internal combination valves must be removed if the container is to be steam cleaned. Heat can damage the valve's seats and seals.
6. Standard construction internal combination valves are not designed for water service. Immediately after a container is hydrostatically tested, remove all water and allow the container to thoroughly dry out.

Parts Ordering

Important

Use only genuine MEC replacement parts. Components that are not supplied by MEC should not, under any circumstances, be used in any MEC valve, because they might adversely affect the performance of the valve, and could give rise to personal injury and property damage.

When corresponding about this equipment, always reference the equipment model or series number found on the nameplate.

Valve	
Available Service Kit	ME990-10-SRK
	ME990-10-PGA
	ME1000-10-BRK
	ME1000-10-SRK
Additional Strainer Options	ME1000-10-HRK
	20 Mesh - ME1000F-10-20
	80 Mesh - ME1000F-10-80
	100 Mesh - ME1000F-10-100

SRK – Seal Repair Kit
PGA – Packing Gland Assembly
BRK – Bonnet Repair Kit
SRK – Seal Repair Kit
HRK – Handle Repair Kit

See parts list for corresponding parts and service kit components.

ME1000-10

Parts List for ME1000-10				ME990-10-		ME1000-10-		
Ref. #	Description	Qty		SRK	PGA	BRK	SRK	HRK
1	Body	1						
2	Strainer	1						
3	Bonnet Sub-Assembly	1					✓	
3a	Bonnet Body		1					
3b	Bonnet Stem		1					
3c	Bonnet Valve Holder		1					
3d	Pilot O-ring		1					
3e	Retention Washers		2					
3f	Bonnet Valve Holder Retainer		1					
3g	Gland Holder		1					
3h	Gland Holder O-ring		1					
3i	Female Packing Adapter		1			✓		
3j	Male Packing Adapter		1			✓		
3k	V-Pack		2			✓		
3m	Packing Spring		1					
3n	Inner Packing O-ring		2			✓		
3p	Outer Packing O-ring		1			✓		
4	Handwheel	1						✓
5	Handle Info Plate	1						
6	Handle Lock Washer	1						✓
7	Handle Hex Nut	1						✓
8	Bonnet O-ring	1				✓	✓	
9	Internal Valve Gland Assembly	1		✓	✓			
10	Gland Assembly O-ring	1		✓	✓			
11	Gland Assembly Retainer	1						
12	Socket Head Cap Screw	2						
13	Valve Stem	1						
14	Valve Spring	1						
15	Valve Spring Washer	1						
16	Excess Flow Spring	1						
17	Excess Flow Washer	1						
18	Valve Holder	1						
19	Valve Seal	1		✓				
20	Excess Flow Seal	1		✓				
21	Seal Retainer	1						
22	Nut	1						
23	Nameplate	1						
24	Nameplate Screw	2						
25	Lever Arm	1						
26	Stem Cotter Pin	1						
27	1/4" NPT Plug	1						
28	NPT Plug Adaptor	1						
29	1/2" NPT Plug	1						

ME1000-10

